

WIRING & ELECTRICAL CONNECTIONS

Up to 16 dampers/shutters can be connected using a 3-core cable arranged in a ring (diagram A). Using 1mm² wire will allow a ring system with a maximum circumference of 100 metres. If a radial or spurred system is to be installed, the maximum length of each leg will be 50 metres. These lengths can be increased proportionally to increments of wire cross sectional area. Using a spurred system may limit the number of dampers that can be connected to a DCM (diagram B).

Damper Control Monitors should always be located where they can be routinely viewed or a audio warning options should be incorporated and positioned where they can be heard by a responsible member of staff.

Wiring installations and commissioning should only be undertaken by qualified personnel working with Lorient wiring, fitting and commissioning instructions. A completed wiring diagram for each installed system should be passed to the building operator after commissioning. The diagram should indicate the location of each damper and its DCM address.

A three wire cable is required to connect the Damper Control Monitor (DCM) to the dampers. Using 1mm² wire provides a ring system of a maximum circumference of 100 metres. If installed radially or spurred, the maximum length is 50 metres. These lengths can obviously be increased with increments of wire cross sectional area.

Since Talkback is a multiplex system and therefore only one damper is being activated at any one time, only the length of the longest spur need be taken into account on an installation where a ring serves several spurs.

Generally 1mm² flat twin and earth cable is acceptable for the Talkback system, since in the event of cable failure due to a fire, the system will automatically fail safe to the closed position. However, it is advisable to check with the local fire officer that such cable does not conflict with local policy. In which event, fire resistant cable may be used so long as it provides at least the same capacity as 1mm² copper wire.

Each damper/air transfer grille within a system has an individual code; therefore a 3-core cable is employed in order to provide a means of supply and signaling to each unique address.

Please refer to Lorient wiring diagrams and the comprehensive fitting instructions before attempting installation.

WIRING LAYOUT

TALKBACK DAMPER CONTROL SYSTEM - SCHEMATIC WIRING INSTALLATIONS

DIAGRAM A:
Ringed wiring
installation

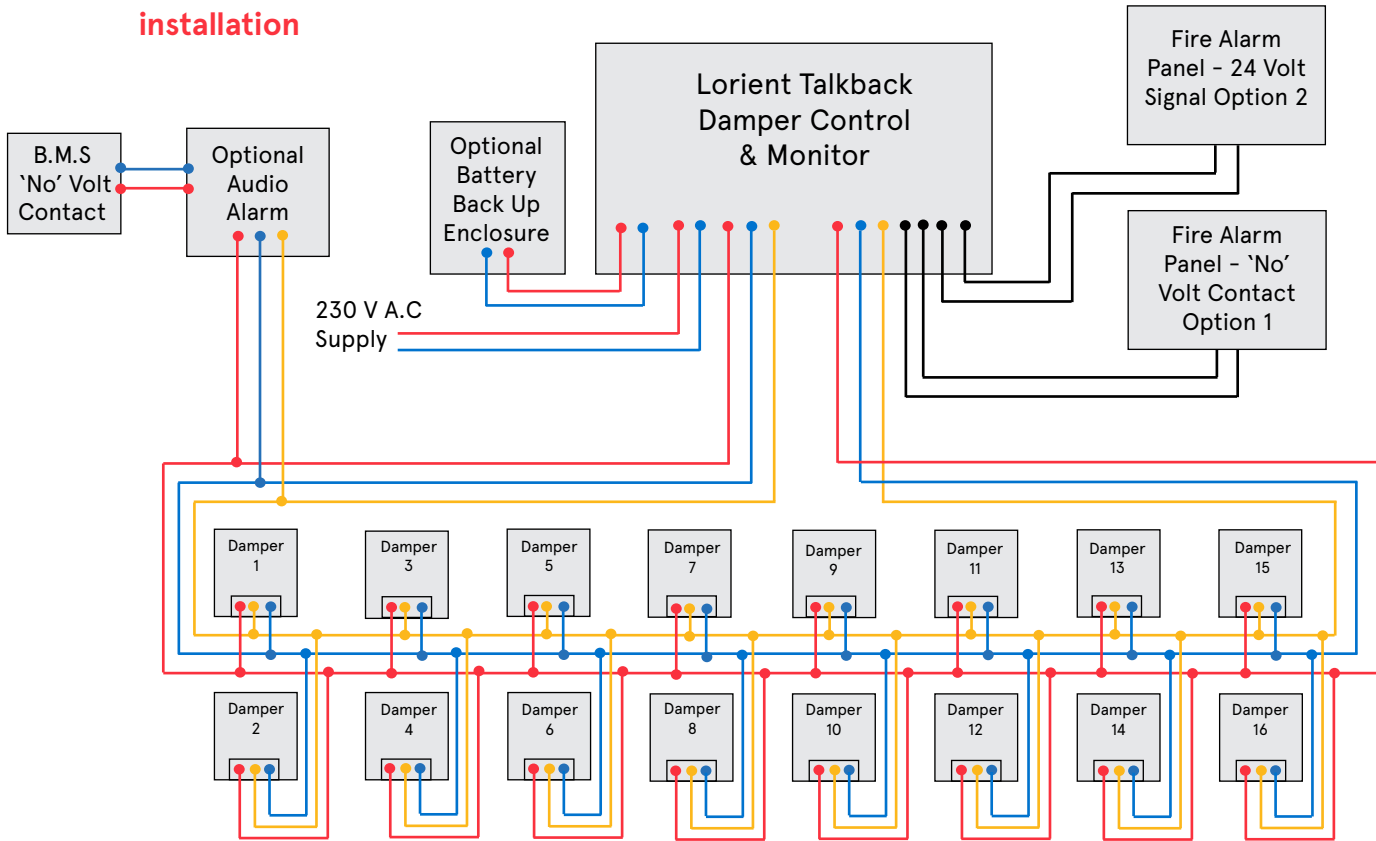

DIAGRAM B:
Spurred wiring
installation

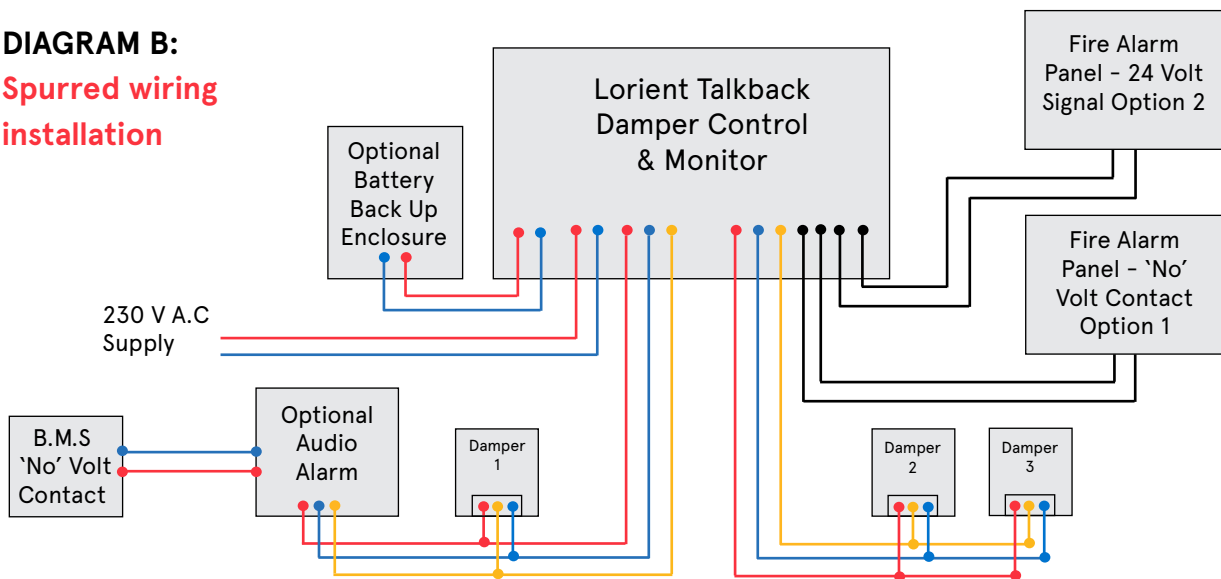
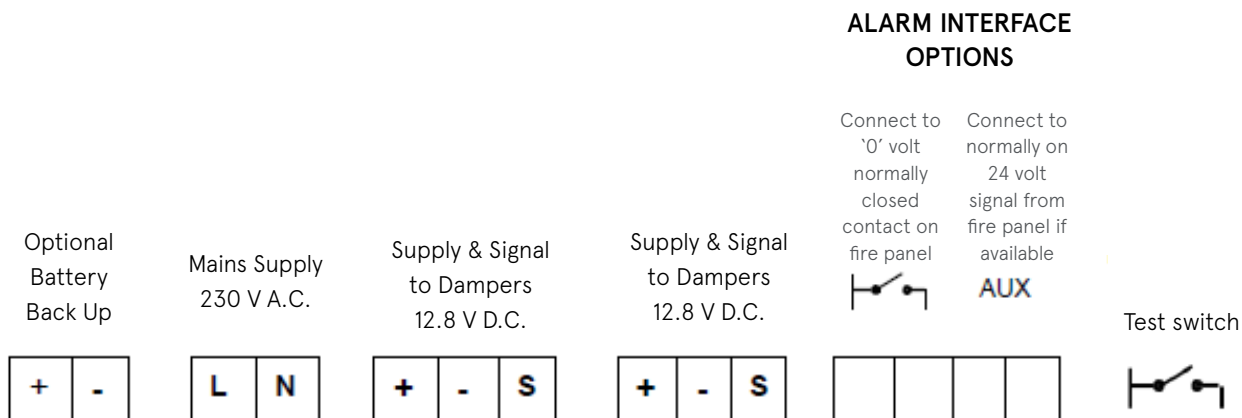

DIAGRAM C: Connections within Talkback Damper Control + Monitor



Each DCM can control up to 16 air transfer grilles or dampers. Each air transfer grille or damper must be assigned its own address from 1 to 16. A shared address will cause the system to fail. The address of any damper can be changed by adjusting the rotary switch on the front of the actuator as shown in below.

As we are unaware of the placement of the individual dampers we cannot set the address to correspond with the damper control system. Each unit should only have 1 x no. 1, 1 x no. 2, 1 x no. 3, etc connected to it.

PLEASE ENSURE YOU SET THE ADDRESS ON THE ACTUATOR BEFORE CONNECTING THE SYSTEM TO THE MAINS SUPPLY.

This is done by using a small flat bladed screwdriver and turning the rotary switch.

Options shown: 1 2 3 4 5 6 7 8 9 A B C D E F O
 Equates to: 1 2 3 4 5 6 7 8 9 10 11 12 13 14 15 16

The pictures below show the location of the rotary switch:

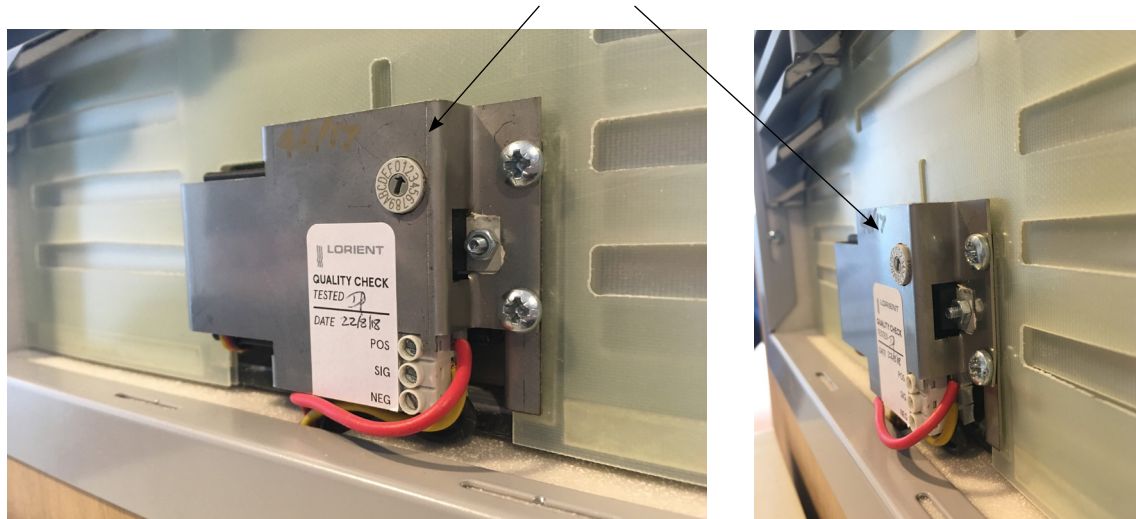

WIRING & ELECTRICAL CONNECTIONS

FIRE ALARM CONNECTION OPTIONS

"Talkback" DCM units can be connected to fire alarm panels in two ways, the most popular of these being option 1, shown in diagrams "A, B & C", where the DCM sends its own signal to a "0" volt contact on the alarm panel. This requires no output from the fire alarm panel but in an alarm condition the normally closed contact opens and breaks the signal. The DCM instructs all dampers to close when the signal fails.

The second option shown in the same diagrams use a 24 volt signal generated by the fire alarm panel in normal conditions but which ceases in an alarm conditions. The loss of the signal triggers the DCM to instruct the dampers to close.

OPERATION

In normal conditions air transfer grilles or dampers will be in the open state and the same number of green lights on the top row of the DCM as there are grilles or dampers connected, will be illuminated. This indicates that the grilles/dampers have been instructed to be open and that they have complied with that instruction.

During auto-cycling or manual testing the normal interface signal between the fire alarm panel and the DCM is interrupted. A red warning light flashes at the top of the DCM which then instructs the dampers to close. Initially the bottom row of green lights are illuminated to indicate that instruction to close has been given and if all grilles/dampers have closed the number of lights coincident with the number of grilles/dampers connected remain illuminated.

If after approximately 20 seconds one or more green lights are replaced by a red light on the middle row, a fault is indicated against that or those grille(s)/damper(s). The 20 seconds delay is caused by the DCM needing to interrogate each actuator in the system in turn and to receive each response.

The auto-cycle will automatically reset the DCM to give the instruction to open. Again any grilles/dampers that have not fully opened will cause red lights on the middle row to light up and the equivalent green light on the top row will be extinguished after about 20 seconds.

Manual testing can be undertaken without activating the fire alarm panel by disconnecting the alarm interface wiring, bridging the terminals marked.

Testing can then be undertaken using the rotary test switch shown in Diagram C.

MAINTENANCE

AIR TRANSFER GRILLE MAINTENANCE

If a fault should develop on any air transfer grille, the cover grille or intumescent fire grille should be removed to expose the shutter plates and actuator. The wiring connections should be examined for looseness and refitted or tightened as necessary. The shutter plates should be checked for jamming due to distortion caused by impact damage or debris trapped in between the plates. If debris is causing a failure to close, reset the DCM to the open condition and clean the plates using a paint brush.

Do not attempt to remove the actuator from the shutter plate assembly or to dismantle the shutter plate assembly.

If the problem cannot be resolved contact the manufacturer. If a condition arises where all shutters fail to operate as instructed and only red lights are illuminated, refer to the Lorient fault finding chart.

DUCT MOUNTED DAMPER MAINTENANCE

If a fault should develop on a cassette type smoke containment damper, the cassette retaining screw should be removed allowing the shutter assembly to be slid from the damper housing and will allow the shields to be removed from the actuator. The shutter plates can then be examined for debris and cleaned or the actuator wiring connections may be checked and tightened or refitted as necessary.

Do not attempt to remove the actuator from the shutter plate assembly or to dismantle the shutter plate assembly.

If the problem cannot be resolved contact the manufacturer. If a condition arises where all shutters fail to operate as instructed and only red lights are illuminated, refer to the Lorient fault finding chart.

GENERAL MAINTENANCE

The auto-cycling feature of the "Talkback" system does not usually allow dust and debris to accumulate in such a way as to inhibit the moving parts of the shutter plates or actuator. If accumulations regularly occur in air transfer grilles it suggests that the circulating air quality within the building is very poor and should be addressed as a serious health issue. Where this situation occurs in dampers mounted in ventilation ducts, it suggests that the in line filtration system is ineffective and should be investigated.

FAULT FINDING

PLEASE NOTE

It is important to be aware of the following information concerning the shutter control system when fault finding:

The top row of green lights of the control unit indicate:

- a) Initially that the control unit has instructed the damper or shutter to open.
- b) 20 seconds later if the green light is still illuminated the damper or shutter has successfully executed the instruction.

The centre row of red lights marked NULL on the control unit when illuminated indicate either:

- a) Failure of a shutter to follow the last command from the control unit if connected. The red light may take 30 seconds to illuminate after the command was transmitted whilst the system interrogates and responds for each channel.
- b) No shutter is connected to this channel.

The bottom row of green lights of the control unit indicate:

- a) Initially that the control unit has instructed the damper or shutter to close.
- b) 20 seconds later if the green light is still illuminated the damper or shutter has successfully executed the instruction.

Ensure that sufficient time is allowed for the system to stabilise when initially powered up. Also allow sufficient time for control unit commands to be received by the actuators and confirmation from the shutter or damper actuators sent back to the control unit.

Before conducting a lost power "Fail Safe" test, at least 4 minutes must be allowed from powering up the system in order to ensure that all capacitors have been adequately charged.

Fault symptoms on this chart have been arranged in the most likely order that they may be encountered during commissioning.

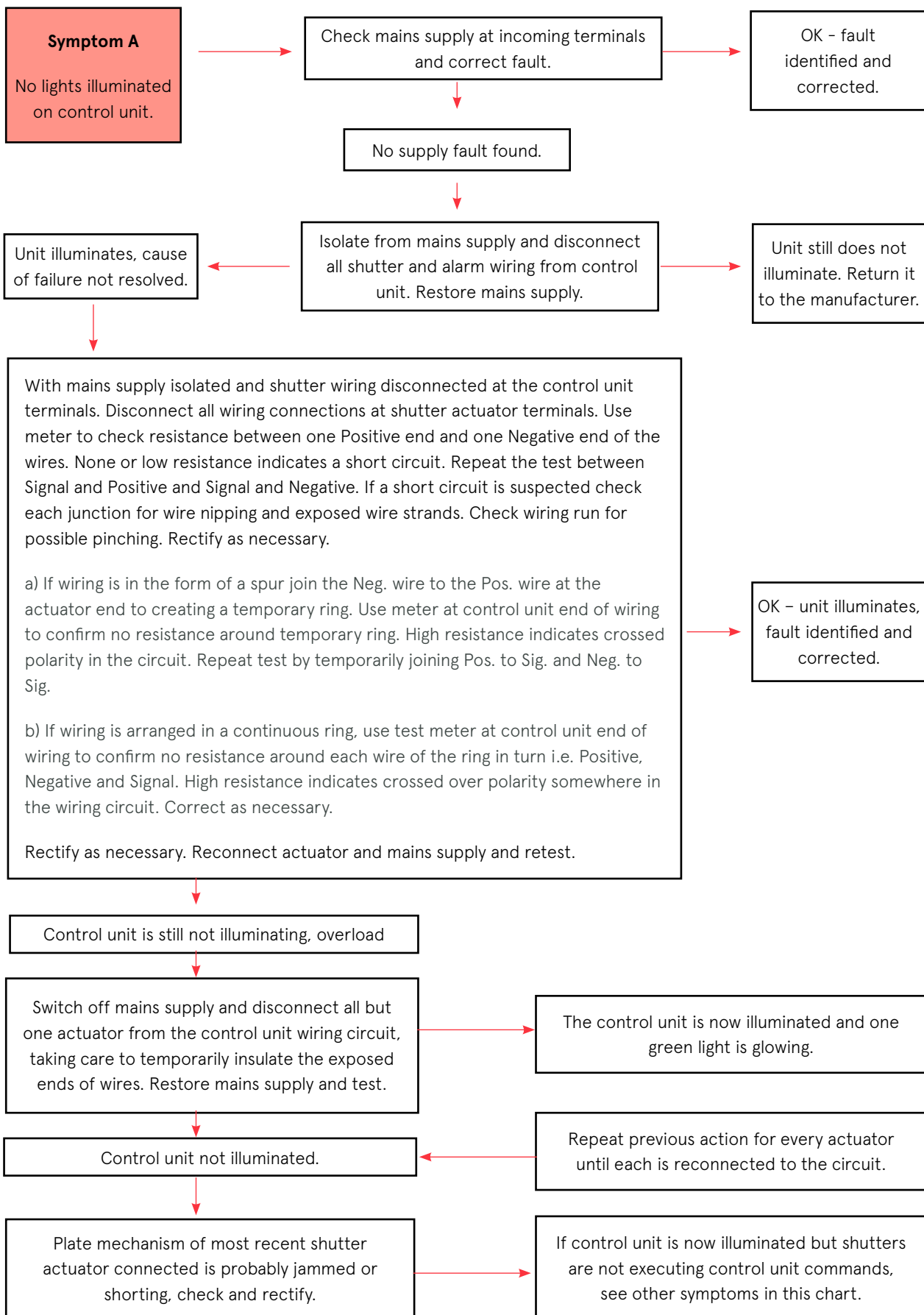

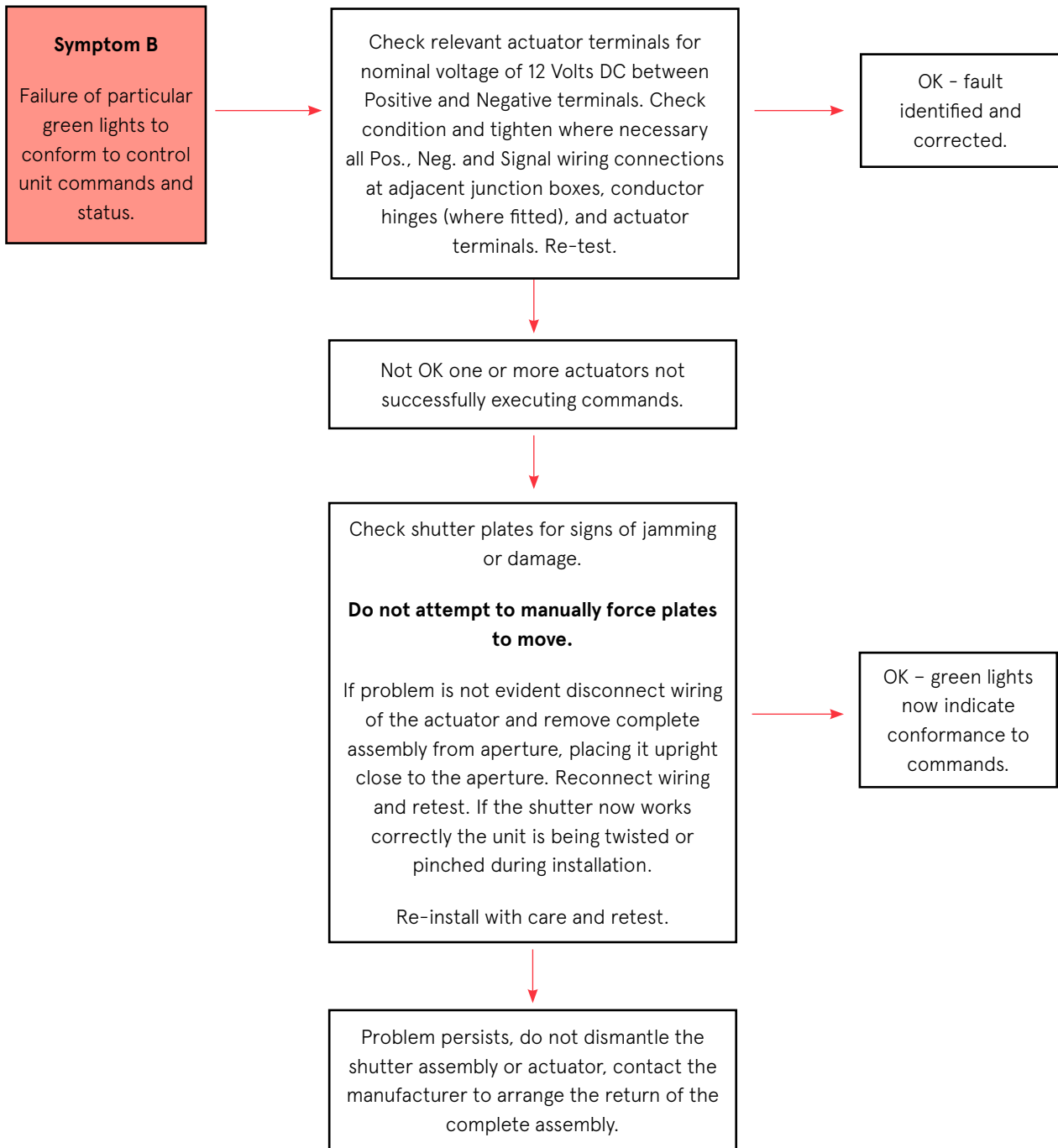

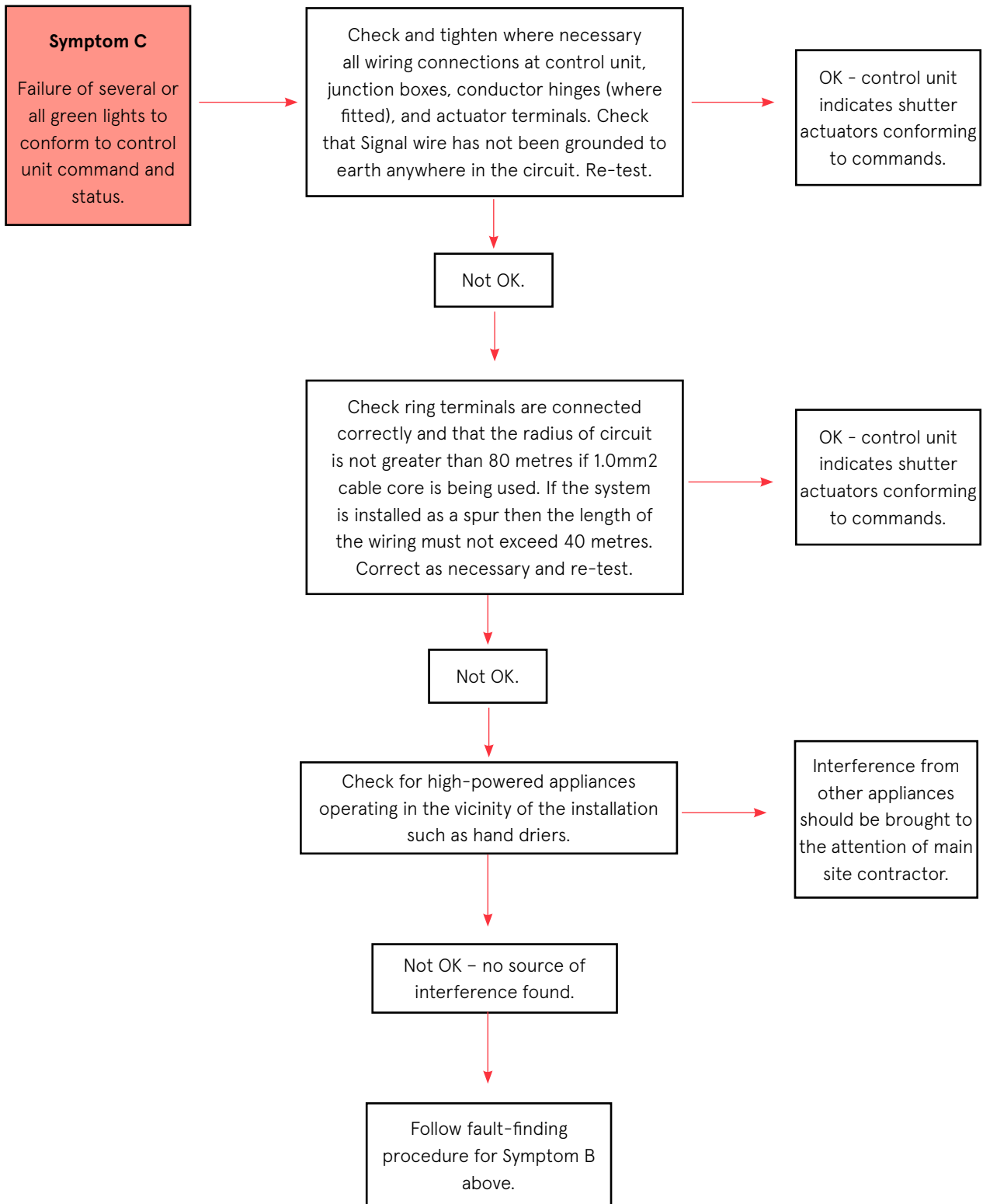

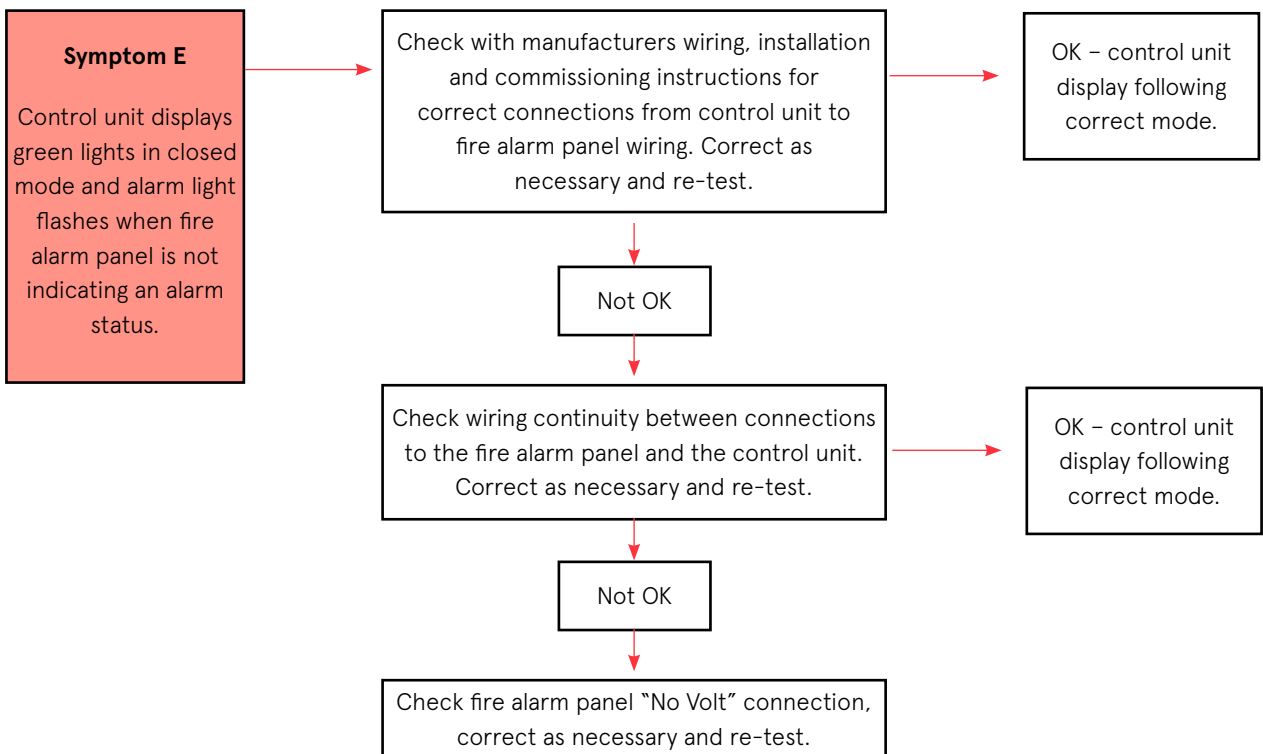
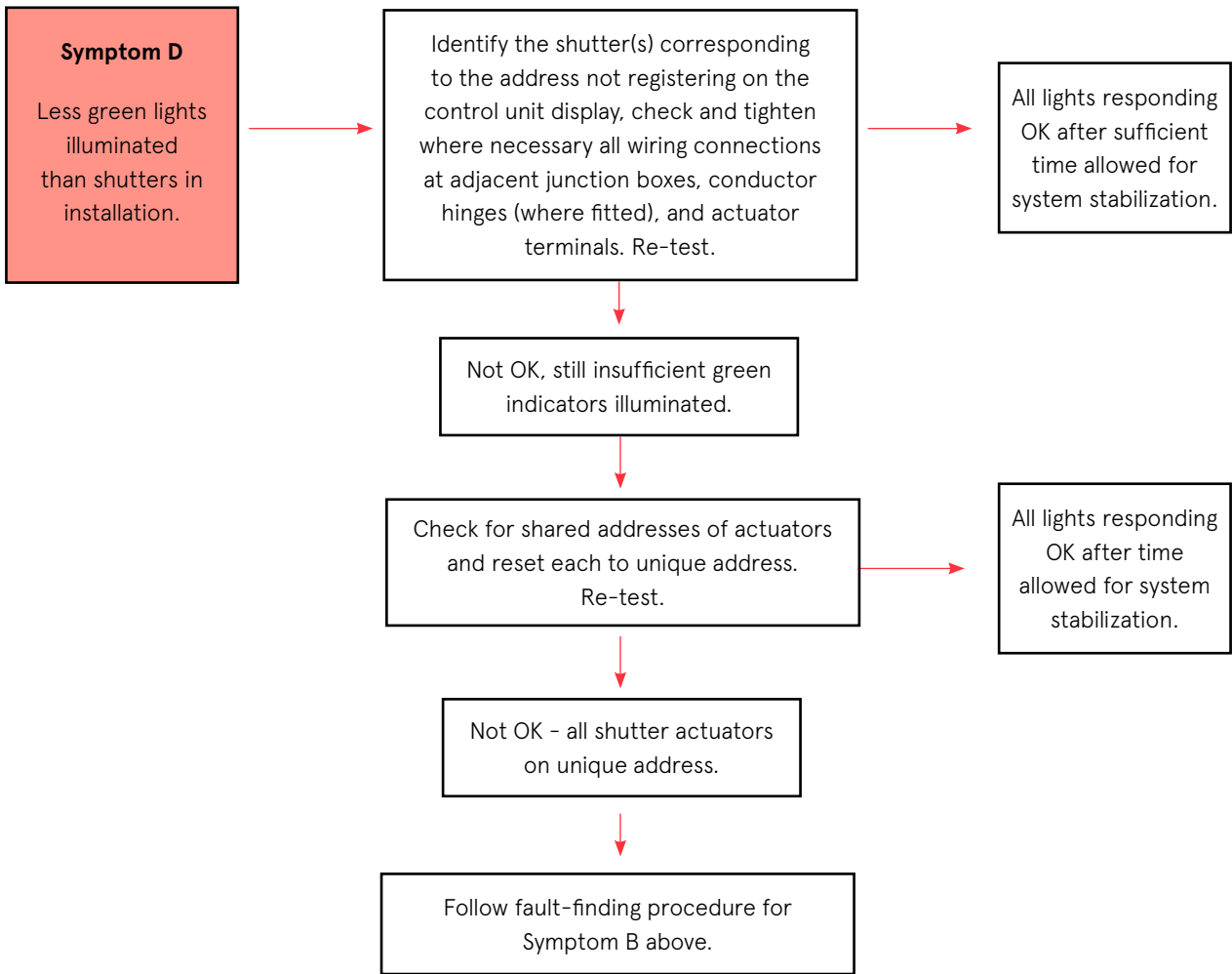

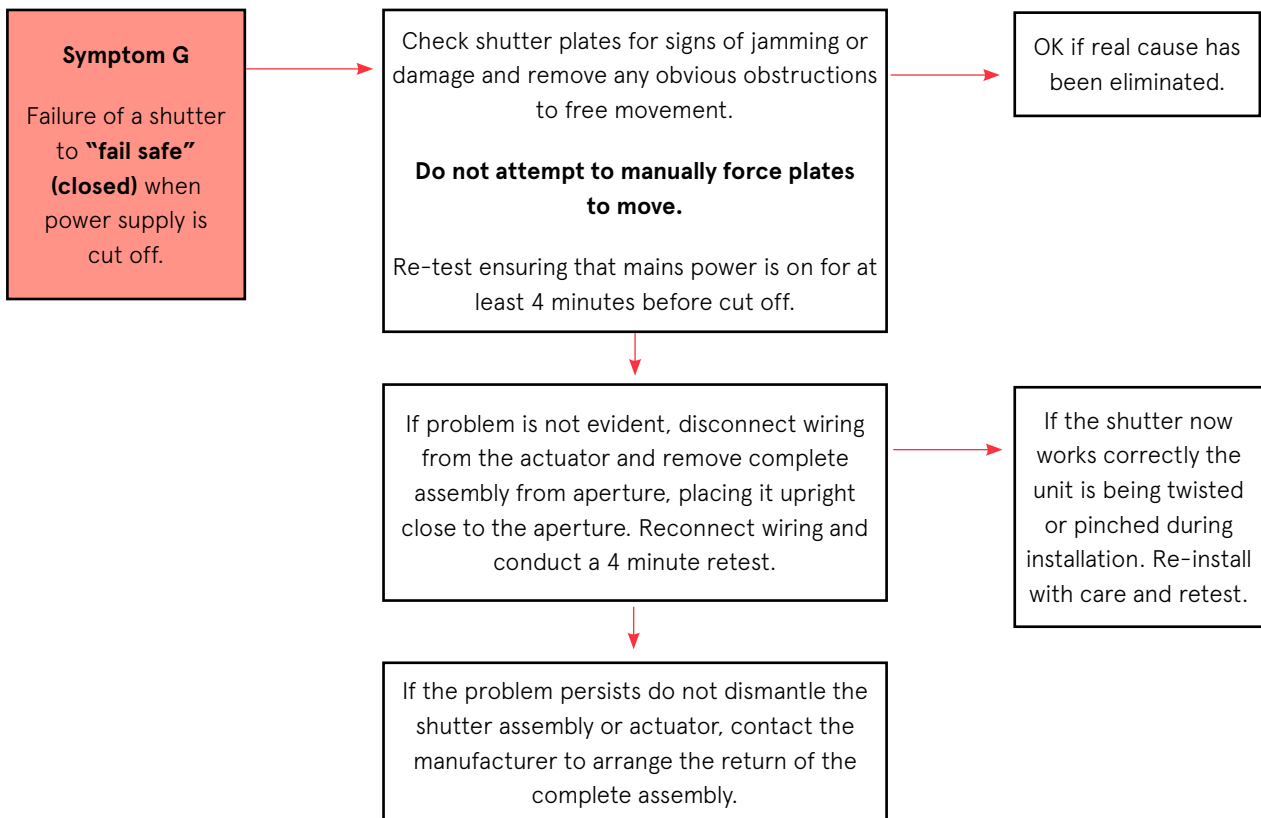
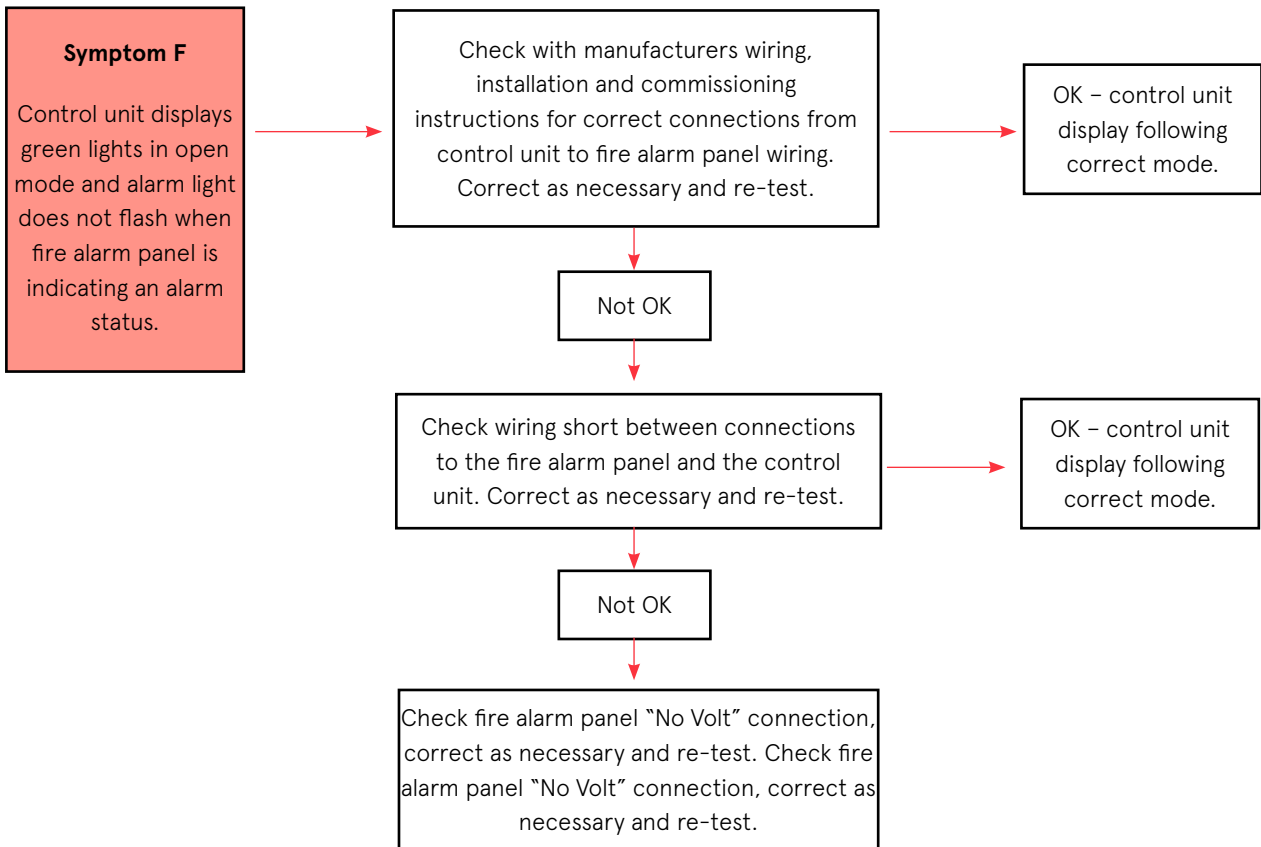

SEQUENTIAL TEST METHOD TO IDENTIFY FAULTS ON "TALKBACK" LOOP INSTALLATIONS

IMPORTANT NOTES:

1. There must be an adequate 240 Volt AC supply to the Control Unit.
2. The DC supply at any point around the loop should not be lower than 10.5 volts.
3. Cable should not exceed the lengths recommended by Lorient for wire cross sectional areas used in the installation.
4. This test method will only work if the damper addresses are coincident with the actual order of dampers around the loop. Check that addresses are in the actual order before starting the test sequence, correct as necessary by changing the addresses on the actuators.
5. Make sure that no dampers share the same address.

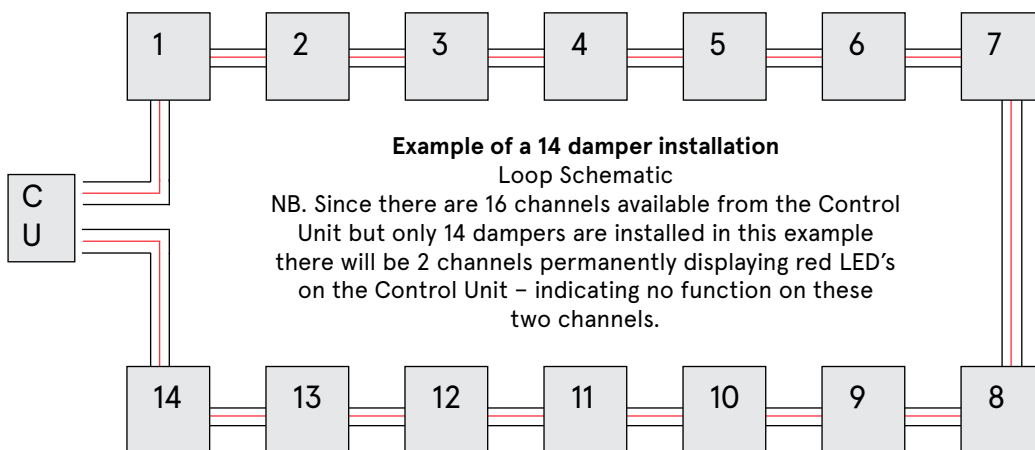

Example of fault:

Symptoms – Control unit displays green lights for all dampers in circuit when in closed mode.

When open mode selected, green open LEDs flash but system keeps defaulting to green closed LEDs.

The system is doing what it is designed to do. Failing Safe - it recognises that a fault exists and therefore will not allow the fire and smoke dampers to open until the fault is rectified.

Possible causes:

- AC supply to Control Unit is inadequate – check and rectify if necessary.
- Short circuit on signal or supply cables in loop.
- Dampers sharing same address.
- Poor connections at cable junctions.
- Too much load on the Control Unit.

SEQUENTIAL TESTING PROCEDURE

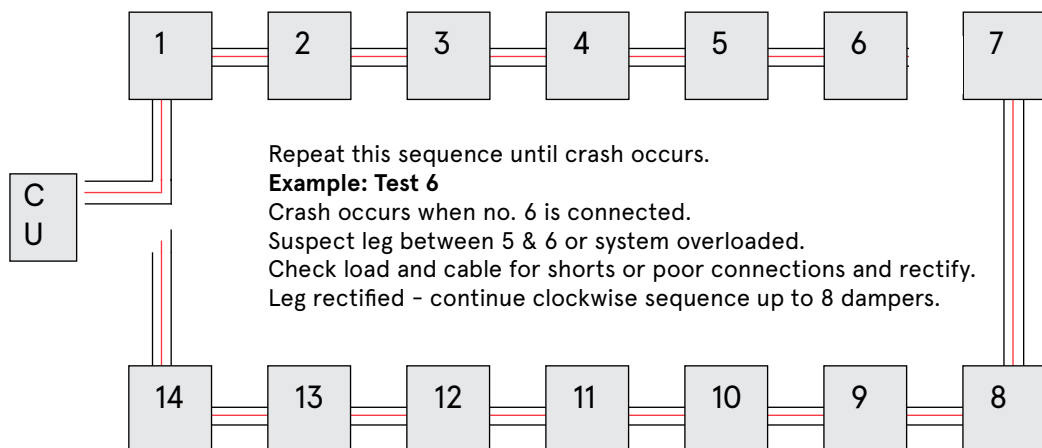
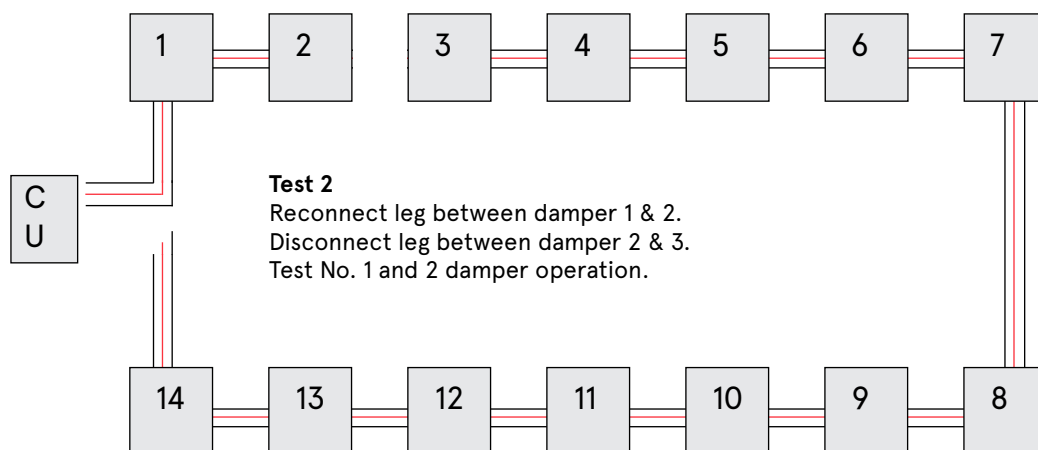
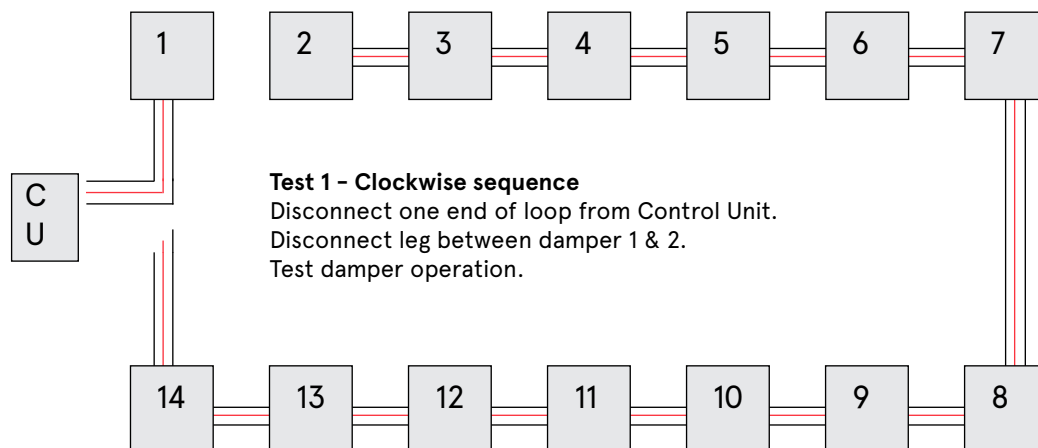

SEQUENTIAL TESTING PROCEDURE

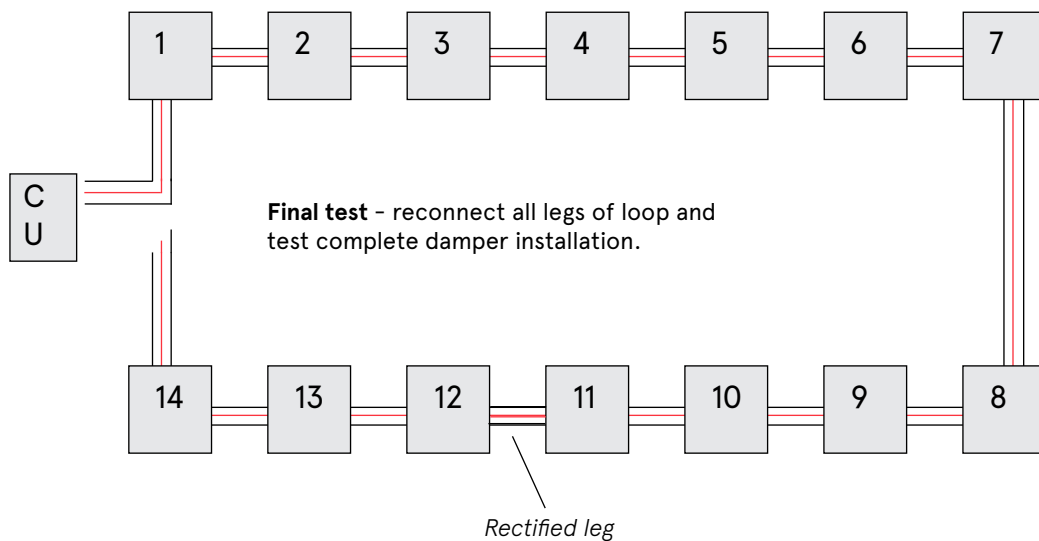
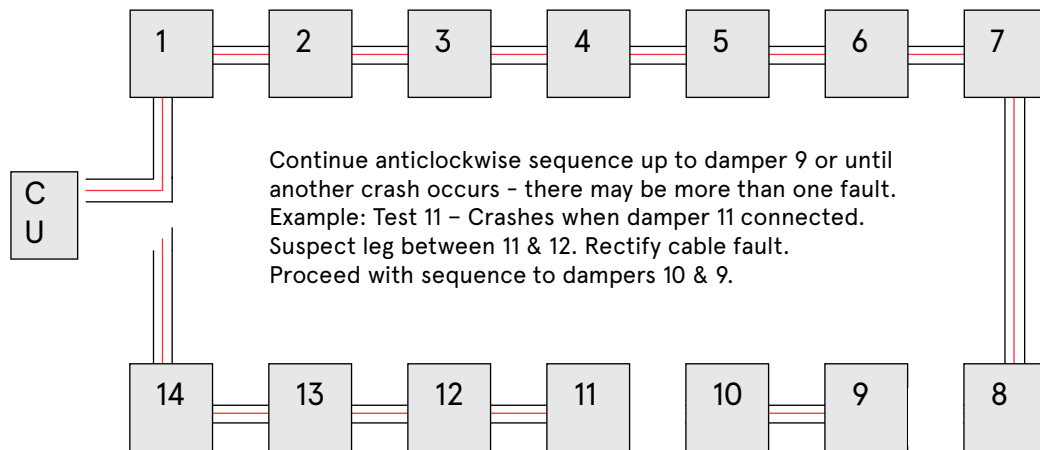
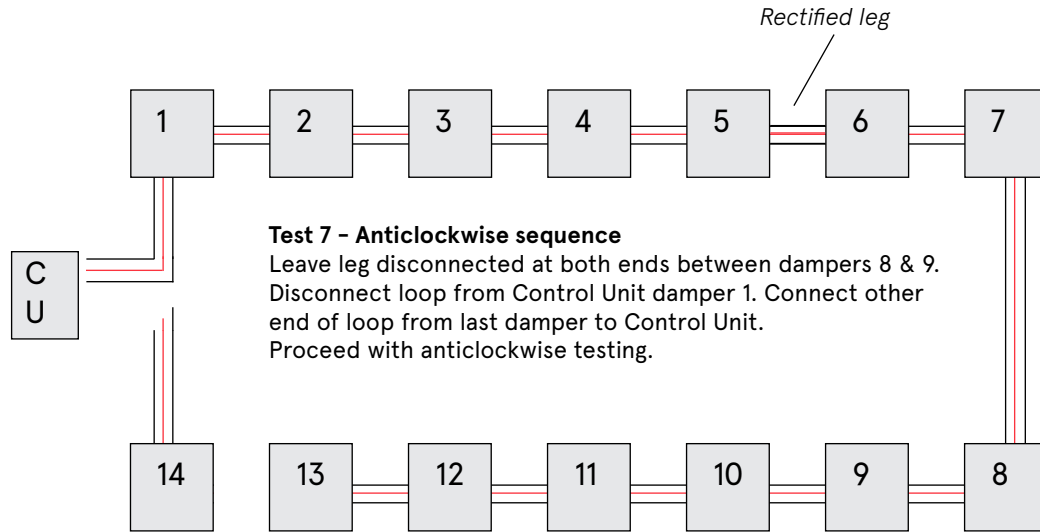



Lorient Polyproducts Ltd

Discovery House, Unit 3
Heathfield Units
Battle Road
Heathfield Industrial Estate
Newton Abbot
TQ12 6RY
United Kingdom

T: +44 (0) 1626 834252

F: +44 (0) 1626 833166

E: testing@lorientuk.com

For further information about
Lorient products please visit:
www.lorientgroup.com



@LorientUK



/company/lorient



@lorientuk



/LorientPolyproducts