



**GUIDE TO
SEALING
SYSTEMS**

GUIDE
SEALING
SYSTEMS





GUIDE TO SEALING SYSTEMS

Contents

	03
Introduction	
<hr/>	
	04
The Function of a Sealing System	
<hr/>	
	05
Door Configurations	
<hr/>	
	06
Door Gaps + Clearance	
<hr/>	
	09
An Overview of Regulatory Requirements	
<hr/>	
	11
Independent Accreditation	
<hr/>	
	12 - 14
Specific Sealing Systems	
Fire Door Assemblies + Intumescent Sealing Systems	
<hr/>	
	16 - 22
Specific Sealing Systems	
Smoke	
<hr/>	
	24 - 28
Specific Sealing Systems	
Acoustic Sealing Systems	
<hr/>	
	30-32
Regulatory Requirements	
<hr/>	
	34-41
Other Considerations	
<hr/>	
	42
Summary	
<hr/>	
	44
Appendix 1	
Methods of Manufacture	
<hr/>	
	45
Appendix 2	
Matrix of Materials, Properties + Finishes	
<hr/>	
	46 - 52
Appendix 3	
Glossary of Terms	
<hr/>	
	53 - 54
Activity Feedback	
<hr/>	
	58 - 59
Additional Information	
<hr/>	
	53 - 54
Comprehensive Support	
<hr/>	
	53 - 54
CPD Seminars	
<hr/>	



This guide has been written as an introduction to the concept of door sealing.

It's designed for students, or those new to the industry who want to learn 'the basics'. It can also be a helpful point of reference when reading product brochures, as a reminder of some of the key points, and for definitions of terms.

In this guide we'll look at fire, smoke and acoustic sealing for doors, around the door's edge (perimeter) and across the bottom (threshold). Some other useful sealing products are mentioned too, such as seals for glass doors and finger guards. We'll also look at regulatory compliance and independent accreditation – and there's a useful glossary of terms at the back. At the end of each section there is an activity you can undertake if you wish, to help reinforce what you have learned.

Although Lorient is a leading name in sealing systems, we've tried to be fairly generic in the information we give here, so you can understand sealing principles first, and then make an informed choice. Plenty more information is available from manufacturers' websites (including our own of course, www.lorientuk.com).

We don't cover glazing seals, hardware protection or air transfer products in this guide. Although these all affect the fire, smoke and acoustic performance of the door, these are separate areas that deserve more explanation in their own right.

Please note: This document has been accredited by RIBA, and qualifies for one hour's CPD.



THE FUNCTION OF A SEALING SYSTEM

Every door assembly will have a gap between the leaf and the frame, so it can operate. However, this same gap will allow fire, smoke, sound and draughts to pass through.

Seals will normally be designed to prevent these unwanted elements moving from one side of the door to the other when the door is closed. If you look closely at a modern architectural door assembly, you'll see that it relies on sealing systems for its performance.

A sealing system will:

- ▶ Fill the gap to prevent or reduce the transfer of these unwanted elements
- ▶ Work with the door assembly to improve aspects of its performance
- ▶ Add minimal resistance to the opening and closing operation of the door
- ▶ Be serviceable in everyday use
- ▶ Be durable in the long term, so that performance is not diminished over time.

In some cases, the seal may be quite specific to a particular environment - but to avoid the need to fit multiple seals, many sealing systems are designed to fulfil a number of functions. For example, a fire seal may very often be combined with an integral smoke seal, and a smoke seal may sometimes function adequately as an acoustic seal.

This drawing shows some of the main parts of a door assembly that we'll mention in this guide.

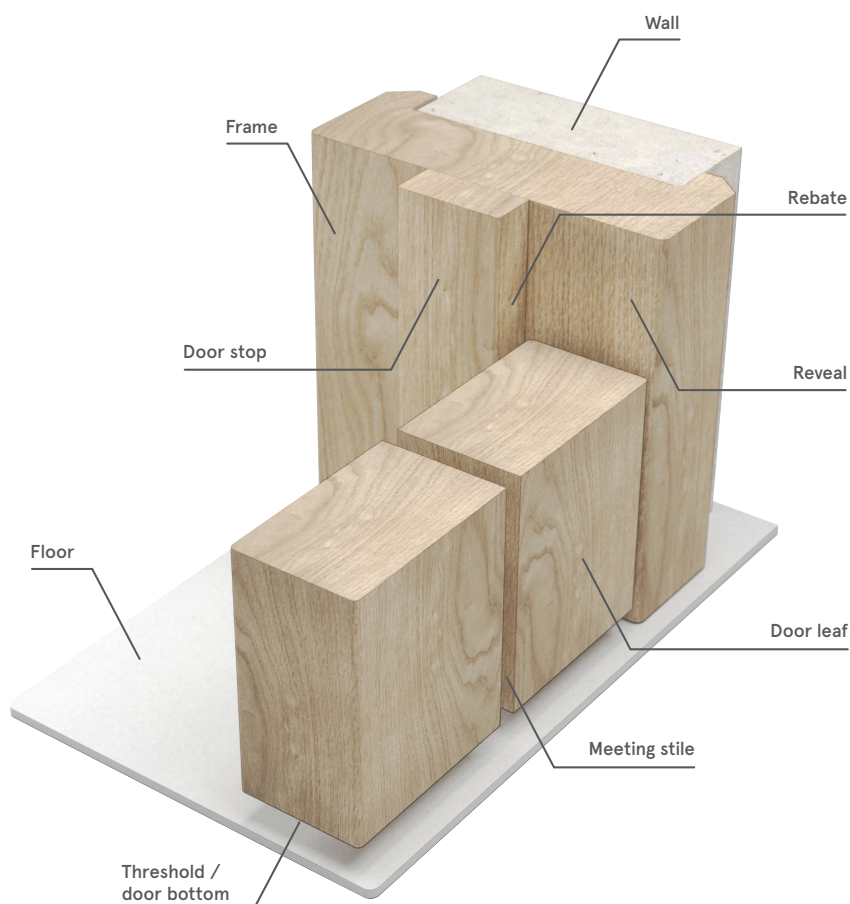

DOOR CONFIGURATIONS

Different door configurations need different sealing systems. That's because doors and seals work together, and different doors have different areas of strength and weakness that the seals need to complement.

Single leaf and double leaf doors behave very differently: you should never assume that a sealing system for single leaf doors will give the same performance on double leaf doors. Some common door configurations are shown below.

SINGLE LEAF DOORS

Single acting / hinged

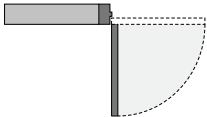

Pivoted / double acting

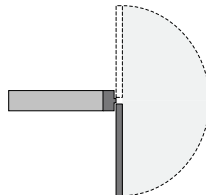

DOUBLE LEAF DOORS

Single acting / hinged
Rebated / unrebated meeting stiles

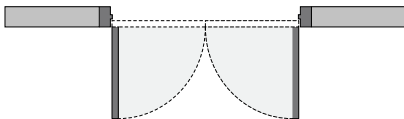

Pivoted / double acting

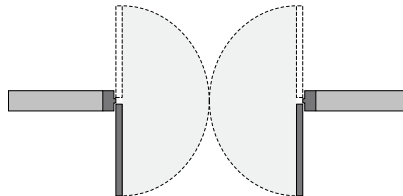

SLIDING DOORS



DOOR GAPS + CLEARANCE

For any sealing system to function properly, the clearances between the door leaf and the frame are extremely important. Smoke, acoustic and thermal seals will need to touch both the door and the frame to be effective; and most seals are designed to suit a 3mm gap between the door and frame. In the case of a seal mounted onto the door stop, the gap can be 2mm between the stop and the face of the door leaf.

The threshold gap tends to be much larger than the perimeter gap. It's also a 'straight-through' gap, with no door stop – so it can be a difficult area to seal, particularly if a smooth transition is required from one side of the doorway to the other, say for wheelchair traffic to meet the accessibility requirements of Document M.

The temptation is to avoid sealing the threshold altogether – but in fact it needs special attention. Leaving the threshold unsealed creates a gap for smoke (and sound) to pass through, to such a level that it will virtually negate the performance of the rest of the sealing system. Some form of threshold sealing is vital to maintain both smoke and acoustic performance.

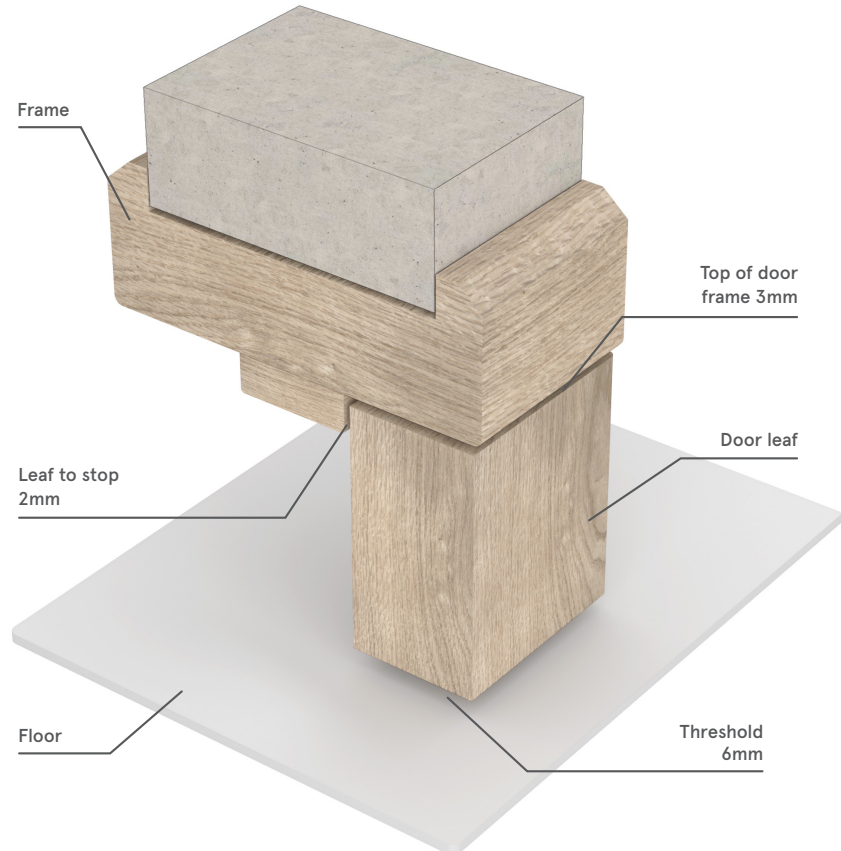



ACTIVITY 1

1. Name 3 types of door configuration:

▶

▶

▶

2. Give 3 reasons why the threshold gap is difficult to seal:

▶

▶

▶

3. Draw a cross section of a door in a frame and highlight the gaps to be sealed:

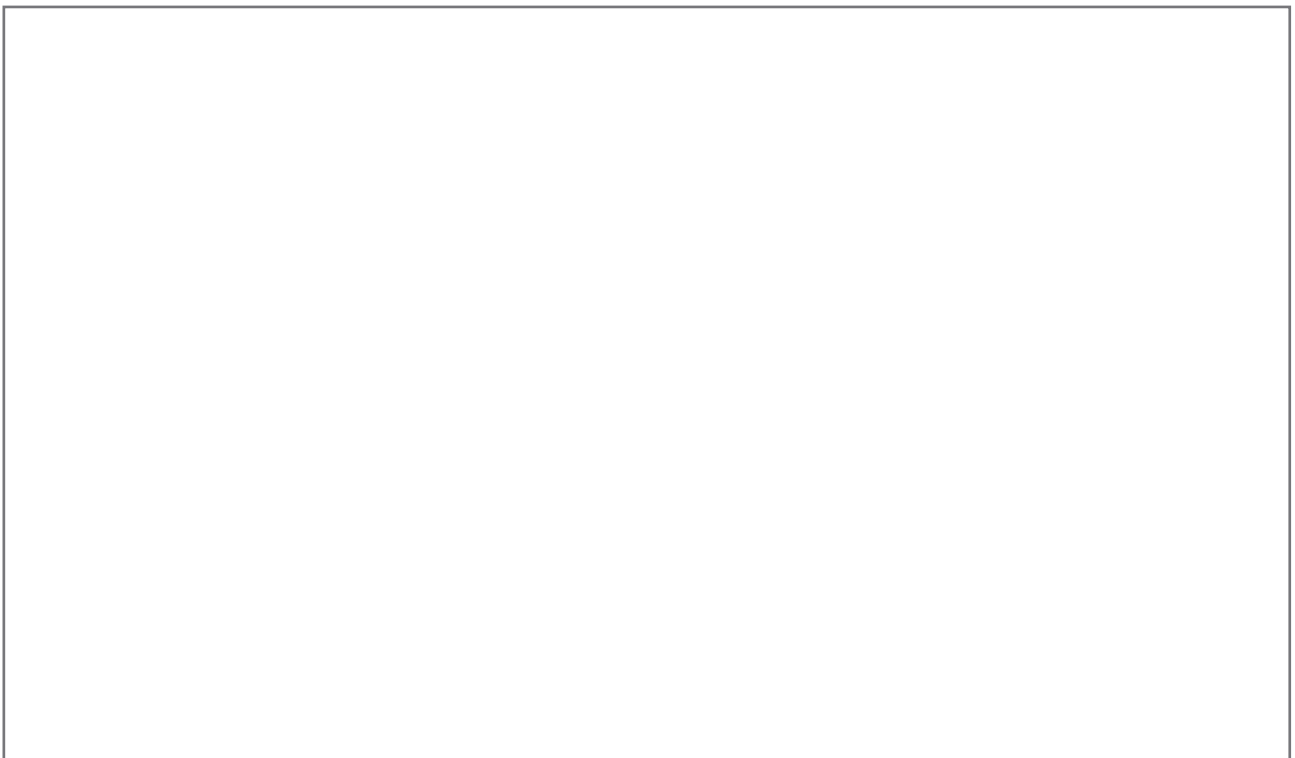

Please refer to the feedback section on page 53 to compare your answers.

AN OVERVIEW OF REGULATORY REQUIREMENTS

The kind of seals needed will generally be determined by the door's location, and what the door needs to do. A timber fire door will invariably need an intumescent seal to meet performance expectations – and practically every fire door also needs to act as a barrier to ambient temperature smoke.

In many situations, door assemblies need to be effective barriers to sound, as well as fire and smoke.

Relevant information can be found in the **Approved Documents to the Building Regulations** (England and Wales) and the similar publications for Northern Ireland, Scottish Technical Handbooks set out the requirements for Scotland.

In the case of fire and smoke, the BS 9999:2017 series of standards are recognised as "Approved Documents" in all jurisdictions.

Meeting the recommendations of the relevant Approved Documents is accepted as evidence of complying with the requirements of the Building Regulations.

We'll cover the specific regulatory requirements for fire, smoke and acoustics more thoroughly in the following sections. But the requirements always apply to a complete door assembly, tested in accordance with a designated standard, and meeting a given performance rating. No part of the door construction on its own will achieve a performance standard or meet the requirements – it's always the combination of the whole door assembly and all its components which has to be tested and proven. It's essential to check test reports closely, as they will always mention which components were tested.



ACTIVITY 2

1. Use manufacturers' brochures or download website information to find out the names of the Approved Documents for England and Wales for Fire, Smoke, Acoustics and Accessibility.

APPROVED DOCUMENTS	ENGLAND	WALES
FIRE		
SMOKE		
ACOUSTICS		
ACCESSIBILITY		

2. Now find out the names of the parallel documents for Northern Ireland and for Scotland.

APPROVED DOCUMENTS	NORTHERN IRELAND	SCOTLAND
FIRE		
SMOKE		
ACOUSTICS		
ACCESSIBILITY		

Please refer to the feedback section on page 53 to compare your answers.

INDEPENDENT ACCREDITATION

Because today's door assemblies rely on sealing systems for their performance, it's important to verify a seal's 'fitness for purpose'. Performance characteristics vary greatly from one seal to another. And as seals are often fitted after the door leaf and frame have been manufactured, it's possible that the correct, tested seal could be substituted with one that won't work in the same way.

Everyday serviceability and consistency of performance in the longer term are crucial too. Certification schemes exist to prove a seal's fitness for purpose, so an independently accredited sealing system will always be far preferable to one without a 'pedigree'.

'**Fitness for purpose**' is an important concept. It's about more than just passing a once-only test for approval purposes in accordance with a British or European Standard. It takes into account the seal's everyday serviceability, as well as how it performs to contain fire and smoke.

So how do we recognise such seals when we go out to buy them or to specify them? Not all seals on the market are capable of delivering the required characteristics: they may have passed the required fire, smoke and acoustic tests – but would they still

be capable of passing those tests after several years of service?

It's worth noting the independent performance appraisal schemes which exist for fire seals and smoke seals, and indeed for door assemblies as a whole. These schemes do all the necessary homework for us, providing a very welcome and valuable safety net.

We'll look in more detail at the specific requirements for fire and smoke seals in the following sections.

With an independently approved product, the **manufacturing process is audited regularly**, and its **ongoing performance is checked**. This gives comprehensive assurance of the product's effectiveness and long-term fitness-for-purpose in everyday service.



SPECIFIC SEALING SYSTEMS

FIRE DOOR ASSEMBLIES + INTUMESCENT SEALING SYSTEMS

A fire door assembly plays an essential role in the compartmentation of a building, acting as a barrier to the passage of flames and hot gases. It must delay the spread of fire for a designated period of time, protecting the escape routes for the building's occupants.

How Doors Burn

Doors hardly ever burn through the middle – they always fail at the weakest point, which tends to be at the edges, where there is more oxygen available to promote combustion. So, it's important to have a well-considered sealing system around the edge of the door.

Additional consideration is needed for ironmongery positions (hinges, locks, latches and concealed door closers) where there is a lot of metal to conduct extra heat into the fixings and the vulnerable surrounding timber.

Doors also fail through the leaves distorting under exposure to very high temperatures, bending away from the frame. An intumescent seal helps to hold the door leaf in place.

Where Fire Doors are Used

Information is detailed in Appendix B of Approved Document B (England), Approved Document B (Wales) and also in the relevant parts of BS 9999:2017.

Nomenclature

Fire door assemblies are designated FD30 for 30 minutes fire resistance, and the suffix "S" is added for smoke resistance – ie, FD30S.

Similarly, FD60 is the reference for 60 minutes fire resistance, and FD60S for the additional smoke requirement.

Another important term for fire door assemblies is that of essential ironmongery. This means the hinges, latch and self-closing device – all critical to the operation of the door in everyday service and especially under fire exposure.

Intumescent Fire Seals

In order to meet the performance requirements of the very onerous fire test regime, every fire door assembly these days is fitted with an intumescent seal. An intumescent material is one which expands under exposure to intense heat. It is designed to fill the normal gap between the door leaf and its frame, blocking off the supply of oxygen in this area to slow down the rate of erosion and charring of the timber.

There are different kinds of intumescent materials, and they exhibit different expansion characteristics. This expansion may or may not be accompanied by a pressure.

Modern intumescent technology is quite complex, and it is always a wise precaution to refer to the door manufacturer in order to determine the correct seal specification for a particular situation. **Only the type of seal shown in the fire test report should be used.**

The Parts of a Typical Fire Seal

In its simplest form, a fire seal will consist of a rigid casing enclosing a central core of intumescent material. Typically, the casing will be of PVC plastic which is designed to provide everyday protection for the otherwise vulnerable intumescent material: it also provides an attractive finish. Under exposure to intense heat, the plastic casing softens at around the same temperature as the intumescent core – so the casing doesn't inhibit the intumescent reaction.

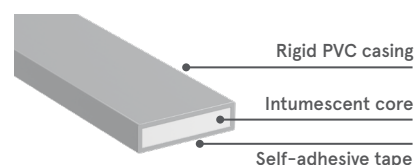

Location of Fire Seals

Wherever possible, the seal should be fitted in the door frame, rather than the door leaf. This is because the door leaf may need to be adjusted when it is being installed to achieve the required fit and clearance gaps. Fitting the seal in the frame means the door can be adjusted without needing to remove and re-fit the seal.

But whether the seal is fitted in the leaf or frame, there will be a negligible difference in performance under fire exposure. Indeed, for some situations, such as the meeting stiles on pairs of doors, it will be essential to fit the seals in one or both of the leaves.

For a standard single leaf hinged door, the seal profile will almost invariably be centrally located in the reveal of the door frame (as shown here). But in other configurations such as double leaf doors, the seal will also be fitted to the meeting stiles.

It should be noted that these are only examples of typical fire seal designs. **It is essential to refer to the door manufacturer's performance accreditation in accordance with the relevant BS test for the exact type and configuration of seals used.**

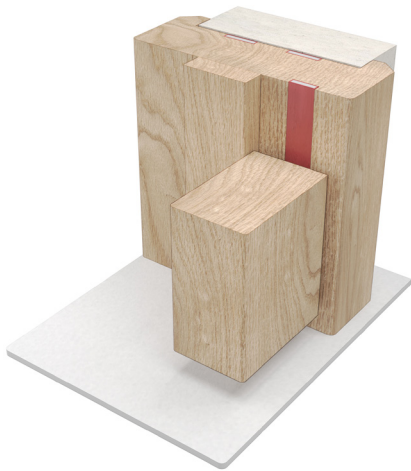

Sealing the Threshold

In practice, it is rarely necessary to fit a fire seal across the threshold of a door assembly, unless the doors need to give unusually high performance such as FD90 or FD120 (note that special door constructions are needed for these levels of fire performance). Under the fire test procedure, it has been found that the doors very rarely fail in the region of the threshold – other areas of the perimeter are far more vulnerable. But again, check the door manufacturer's test evidence.

Test Evidence

A fire door assembly will comply with the relevant requirements when a sample has been tested in accordance with BS 476-22 or BS EN 1634-1:2014 + P1:2018 and has shown that it can maintain its integrity for the designated period of time (eg, 30 or 60 minutes). The time will vary, according to where the door assembly will be installed. An official report confirming the performance will be issued by the testing laboratory.

It is mandatory that fire tests are carried out on **complete, full-size door assemblies**, including the leaf, frame, essential ironmongery and the sealing system. The assembly must be tested in the same way that it will be installed in the wall.

Equally, the tests must be conducted on the **exact configuration of the door assembly** that will be used in practice: for example, a report issued for a test on a single leaf door is not valid for a double leaf assembly; and, likewise, a report issued for a test on a hinged door will not be valid for one mounted on pivots. Separate tests and reports are required for each door configuration. Most door manufacturers will have a whole suite of reports covering their range of products, and these will all show the sealing system used in each case.

It is important to appreciate that the **relevant test procedures (such as BS 476-22 or BS EN 1634) are 'methods-of-test' only, describing how the test is to be conducted and the criteria of failure. They do not stipulate the duration for which a fire door assembly must be exposed to the test regime. Building regulations Approved Documents (such as Approved Document B or BS9999) will define the appropriate compliance, depending on the location – eg, "FD30 when tested in accordance with BS 476-22".**

Independent Accreditation

In practice, it's essential to use an independently approved intumescent fire seal, because the door assembly itself will invariably be independently approved, as will all the critical components used in its construction. The sealing system will need to have its performance verified on a complete suite of full-size fire door configurations; single leaf, double leaf, single acting, double acting, latched and unlatched.

Additional requirements will include:

- ▶ Proven quality of manufacturing materials
- ▶ Proven quality of manufacturing procedures, e.g. BS EN ISO 9001:2015
- ▶ Proven resistance to ageing and possible degradation of the intumescent component in long-term service
- ▶ Agreement by the manufacturer to random, unannounced production audits to verify that ongoing production is to the same specification as that originally tested
- ▶ Commitment to marking of the product with the manufacturer's identification to ensure long-term accountability.

ACTIVITY 3

1. Give three reasons why seals on fire doors help to pass a fire test.

- ▶
- ▶
- ▶

2. Name three instances where you would find fire seals fitted to a door rather than the door frame.

- ▶
- ▶
- ▶

3. List the items that form part of “essential ironmongery”

- ▶
- ▶
- ▶

4. When would you fit a fire seal to the threshold of a door?

Please refer to the feedback section on page 53 to compare your answers.



SPECIFIC SEALING SYSTEMS

SMOKE

You might expect a tested and proven fire door to also provide smoke protection as a matter of course. Unfortunately, this is not so. **If the door doesn't have an additional smoke seal then large quantities of smoke will pass through the perimeter gaps.** Tests show that the conventional stop on a fire door is a very poor smoke barrier. The clearances between the door leaf and the frame, coupled with the pressure, are the critical factors.

The principles of smoke containment are quite different from fire containment, even though the compartment boundaries may be the same. A typical door assembly will quite probably be exposed to smoke, independently of fire (in testing and in practice) – so it needs to be separately designed and evaluated for smoke.

If you look at Approved Document B to the Building Regulations, or the BS 9999:2017 series of codes of practice, you'll see that **practically all internal fire doors in commercial buildings or in houses of multiple occupancy are also required to be smoke resistant to the relevant standards.** This is a very logical requirement, given that the majority of casualties in any fire occur as a result of smoke inhalation, not as a result of burns.

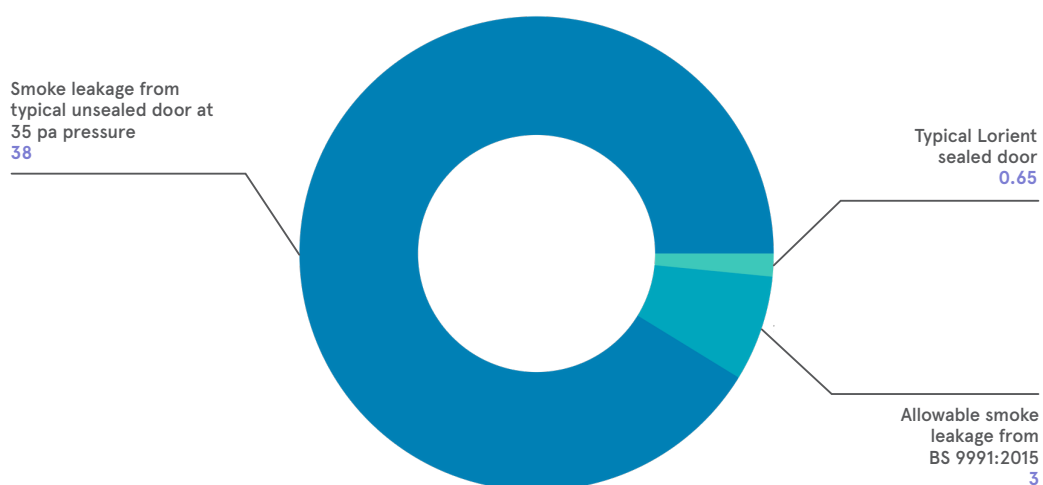

The Components of a Smoke Sealing System

A smoke sealing system will generally be very similar in design to a standard intumescent fire seal. It will typically consist of a rigid PVC casing enclosing a central core of intumescent material – but will also incorporate a protruding flexible brush or fin to bridge the gap between the door leaf and frame.

While it is usual to combine a fire and smoke seal in one compact carrier, sometimes a separate, non-intumescent smoke seal is needed – for example, in fire door upgrade situations. These seals will almost invariably be used in conjunction with an intumescent seal but will be located in a different position on the door assembly. The designs tend to be more diverse, because the seals could be mounted on the stop section of the frame – but there will still be a rigid carrier (perhaps of PVC or aluminium), with a protruding flexible seal to bridge the relevant gap.

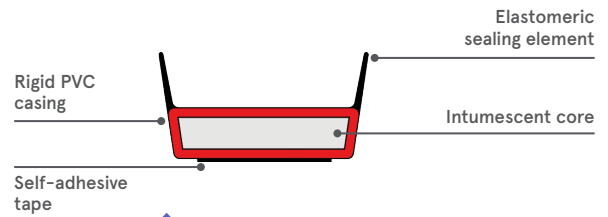

LP1504DS

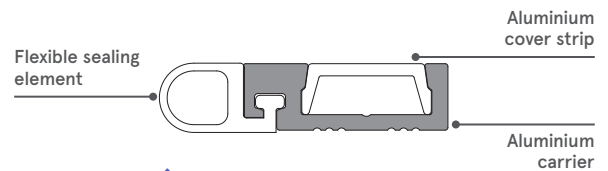

LAS7002 si

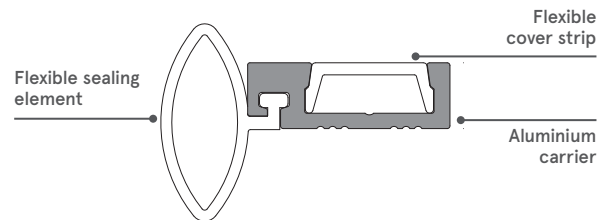

LAS7003 si

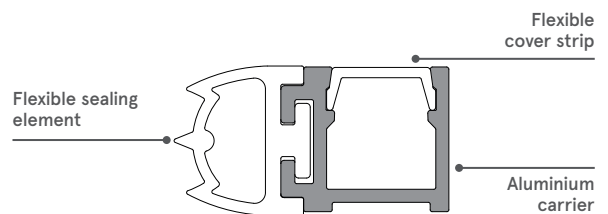

LAS7005 si

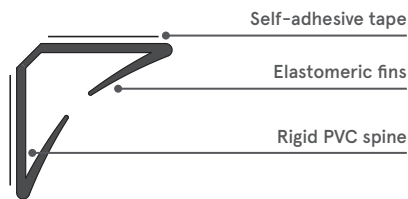

LAS1212
Batwing®



LAS1011
Firtree™

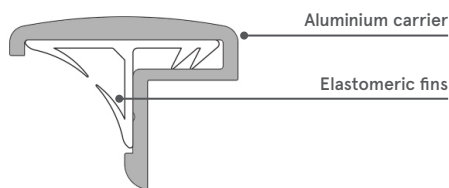

AAS7506
AURA®

The Components of a Smoke Sealing System

Threshold smoke seals are generally more complex. They do not normally incorporate intumescent but will house a mechanism that is designed to automatically lift the seal clear of the floor as soon as the door is opened by a few millimetres. These seals are purely mechanical and no electrical connections are required.

The incorporation of an effective smoke sealing system in a door assembly will typically reduce the transfer of smoke by over 98%.

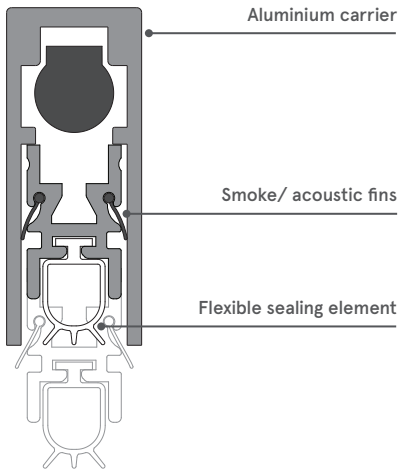

▲ LAS8001 si

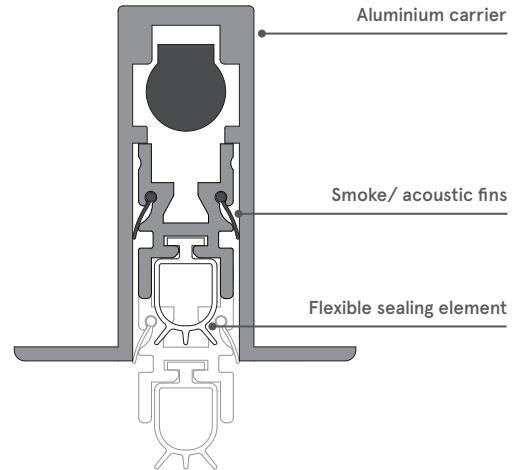

▲ LAS8005 si

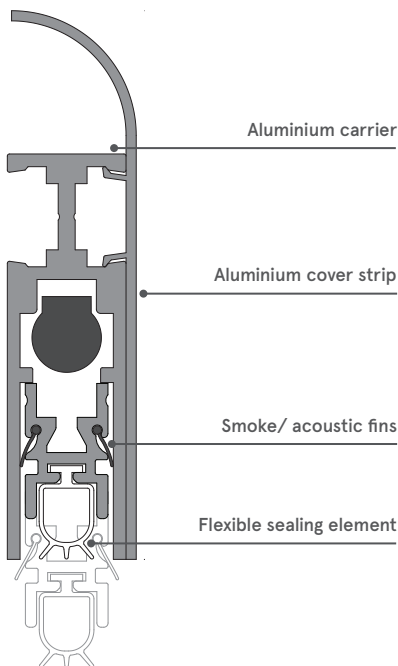

▲ LAS8008 si

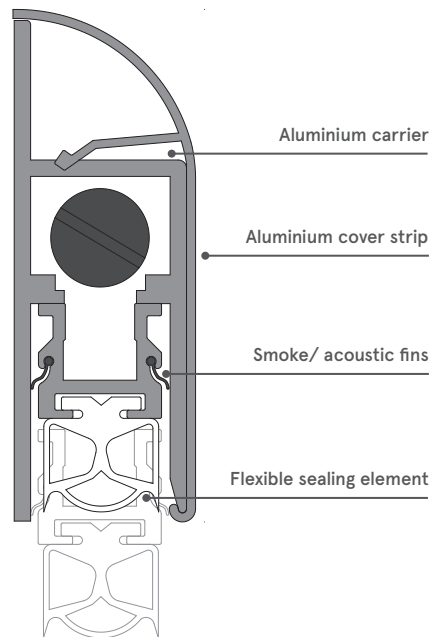

▲ LAS8009 si

LOCATION OF SMOKE SEALS

Perimeter Seals

Around the perimeter of the door assembly, the smoke seal will usually be located in the reveal of the door frame (as shown in image 1), bridging the gap between the door frame and the door leaf. This is especially true if the smoke seal is combined with an intumescent seal.

Non-intumescent smoke seals can be located on the door stop. They can be fitted into the rebate (corner – as shown in image 2), just touching the face of the door leaf in the closed position, with a small amount of compression (no more than 20%).

Alternatively, they can be surface mounted and just touching the face of the door leaf in the closed position (as shown in image 3 & 4).

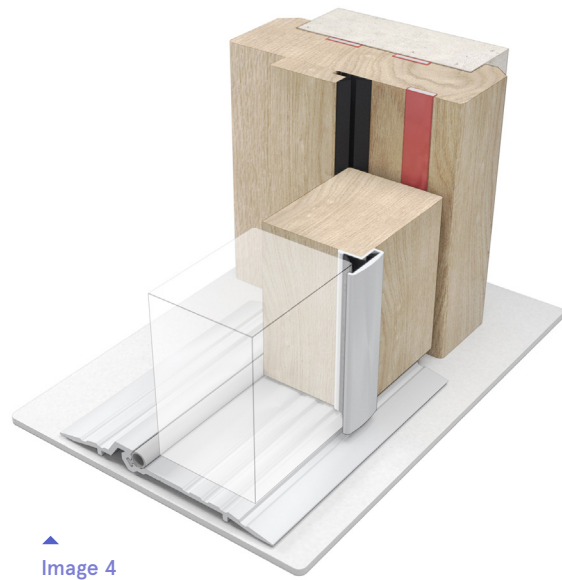

Threshold Seals

Some form of threshold sealing is vital to maintain smoke integrity. The most effective way of doing this is with a drop seal, which may be face-fixed (as shown below right) or concealed within the bottom rail of the door leaf (as shown below left and centre).



Hinges and Other Ironmongery

Although you might expect the knuckle of a standard hinge to provide resistance to the passage of smoke, tests again show this is not the case. The hinges behave in the same way as a straight-through gap: so does the latch. So it is important for seals to be uninterrupted around ironmongery, to maintain optimum smoke integrity.

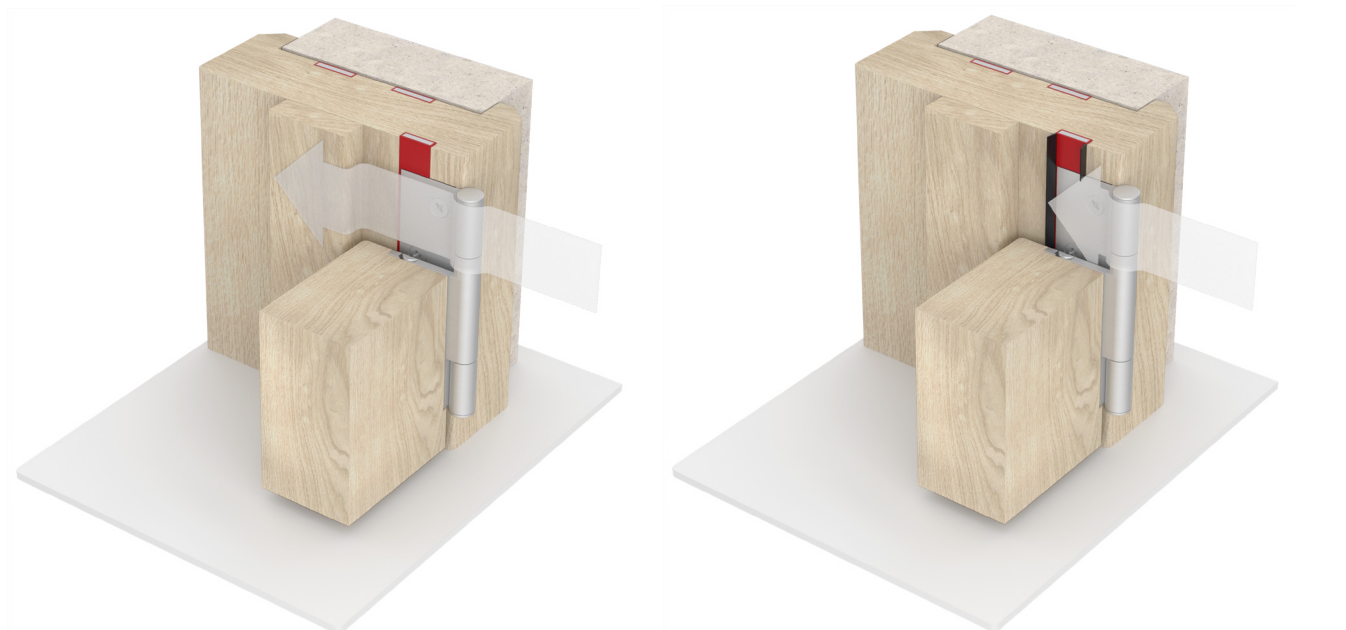

Independent Accreditation

Unlike an intumescent fire seal, a smoke seal will touch the door each time it is opened or closed – so the seal will encounter a certain amount of stress.

It is very simple to wedge a door tightly in the closed position with a crude seal and achieve an excellent barrier to smoke. But in everyday service such a seal would quickly become damaged and building occupants would soon complain that the doors were difficult to operate. On the other hand, seals which do not provide some degree of interference will be poor performers as smoke barriers. **So seal manufacturers have to take both smoke containment and ease of door operation into account.**

Even if the seal manufacturer manages to get the balance right, it is still essential to provide a seal which will withstand many years of continual chafing, abrasion and flexion, without significant loss of performance and certainly without physical breakdown. **A smoke seal may have passed the required initial approval test, but it is vitally important to know that it will still be up to the standard after several years of service.**

For this reason, independent performance appraisal schemes have been introduced for smoke seals – CERTIFIRE, IFC and BBA, as mentioned on page 10.

The BBA accreditation scheme, in particular, demands a very comprehensive level of compliance. As well as laboratory tests, actual installations are periodically checked. **A full reassessment of compliance is also undertaken every three years.**

In addition to the other quality commitments already stated for fire seals (including random manufacturing audits) an independently approved smoke seal must be able to demonstrate:

- ▶ Proven resistance to abrasion and possible breakdown by continually flexing the smoke seal over 100,000 open-and-close movements;
- ▶ Proven performance on a repeat smoke test, conducted under the same BS 476 31.1:1983 exposure, after the above 100,000 open-and-close movements;
- ▶ Ease of operation in everyday service, with strict limits on the amount of extra resistance that can be introduced by the smoke seal.

It's worth remembering that Approved Document M to the Building Regulations (England and Wales) requires door assemblies to meet very stringent levels of opening and closing resistance, in order to provide ease of access to all areas of a building, for all building users.



certifire



ACTIVITY 4

1. List 3 locations where a perimeter smoke seal may be fitted in a door assembly.

- ▶
- ▶
- ▶

2. Why should smoke seals bypass hinges/latches?

3. How does Approved Document M affect fire/smoke doors?

4. Name 4 benefits of having independent accreditation on fire/smoke seals.

- ▶
- ▶
- ▶
- ▶

Please refer to the feedback section on page 54 to compare your answers.



SPECIFIC SEALING SYSTEMS

ACOUSTIC SEALING SYSTEMS

A door assembly needs to be separately designed and evaluated for its acoustic performance. Many doors that need to provide acoustic containment will almost certainly have to provide fire and smoke resistance too.

Door assemblies respond to airborne sound (such as conversation or music), rather than structure-borne sound (such as footsteps or hammering). To reduce the amount of sound which passes from one side of the door to the other, we need to consider two things – the door leaf construction and the sealing system.

Both of these have an effect on performance – but in this document we will just consider the sealing system for a typical architectural door leaf.

Noise containment is not just about keeping out loud noises. Preservation of privacy is just as important – for example, for an apartment entrance door, or a doctor's surgery, a private office or a meeting room.

Sealing System Principles

A door leaf will vibrate when sound hits it, and those vibrations transfer the sound from one side to the other. Sound can also pass through any gaps around the edges of the door – deep door stops or rebated edges won't make a difference to the amount of sound transferred.

The sealing system may also control the transfer of other things at the same time, of course – for example, draughts, dust, smoke and fire. Smoke and fire are particularly important, as many acoustic doors in a building will probably need to be fire and smoke resisting too, due to their location. With careful selection, just one sealing system can perform all these tasks.

Sound is measured in decibels. This unit of measurement takes into account that sound has a pressure to which the human ear responds. It's written as a figure, followed by dB.

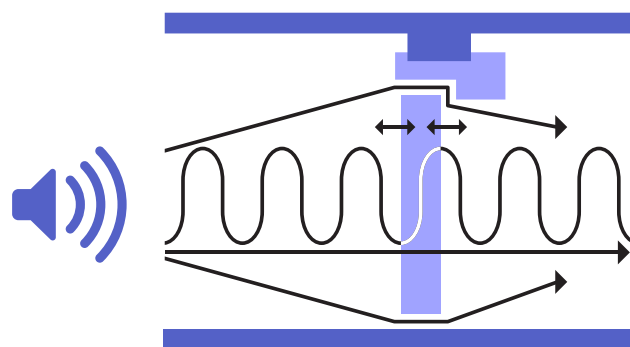

Sound passing through and around a door assembly



Search for acoustic solutions using our online Acoustic Search app

lorientuk.com/acousticsearch

The Components of an Acoustic Sealing System

Given that the majority of acoustic doors will also be required to act as fire and smoke doors, it is quite common to find combined fire, smoke and acoustic seals on a door assembly. But it's important to note that the conventional brush-style smoke seal is not suitable for acoustic applications. The fibres of the brush are fairly porous, so while it will work acceptably well to trap smoke (which is dense and heavy), it won't stop the less dense and lighter airborne sound from passing through. An impermeable fin or multiple-fin seal will work much better, as the table to the right shows.

A combined fire, smoke and acoustic sealing system will therefore be very similar in design to a standard combined fire and smoke seal. It will typically consist of a rigid PVC casing enclosing a central core of intumescent material, and incorporate a protruding flexible seal to bridge the gap between the door leaf and frame.

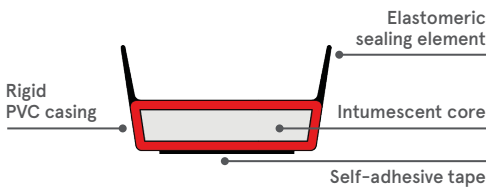

Sometimes a separate, non-intumescent acoustic seal is needed. Like smoke seals, these may be used in conjunction with an intumescent seal but located in a different position on the door assembly. The designs tend to be identical with stop-mounted smoke seals – a rigid carrier with a protruding flexible seal to bridge the relevant gap. Fins and bulb shapes are the norm here, rather than brush seals, so it is usual for the one seal to satisfy both acoustic and smoke requirements.

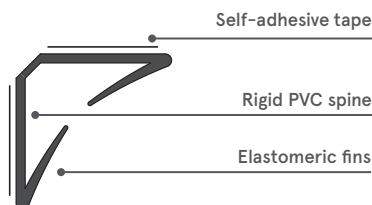

PRODUCT CODE	ACOUSTIC PERFORMANCE	
	Weighted Sound Reduction Index (Rw)	Sound Transmission Class (STC)
LP1504 DS 	31dB	31dB
LP1504 TS 	31dB	31dB
LP1504 AS 	29dB	29dB
LP1504 SS 	23dB	22dB

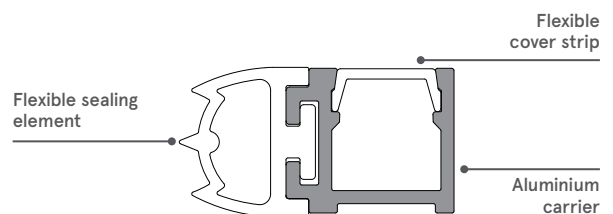

Please refer to page 14 for more examples.

Threshold acoustic seals will also tend to be identical with the equivalent smoke seal – again, it’s usual for the one seal to satisfy both requirements.

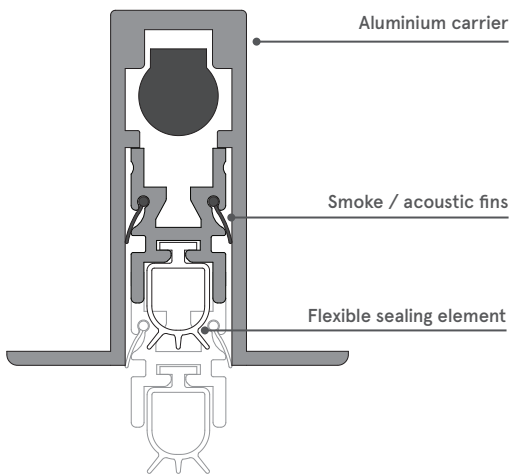

▲
LAS8005 si

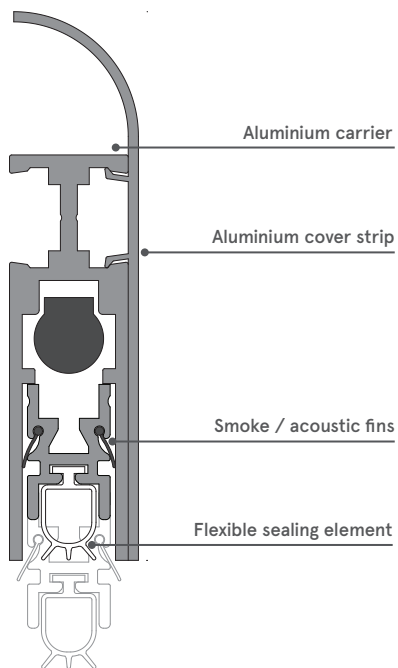

▲
LAS8008 si

LOCATION OF ACOUSTIC SEALS

Perimeter Seals

As with smoke seals, the acoustic seal will generally be located in the reveal of the door frame (as shown), bridging the gap between the frame and the leaf. This is especially true if it is combined with an intumescent seal.

Non-intumescent acoustic seals will again be located on the door stop, either surface mounted and just touching the face of the door leaf in the closed position, or in the rebate (corner).

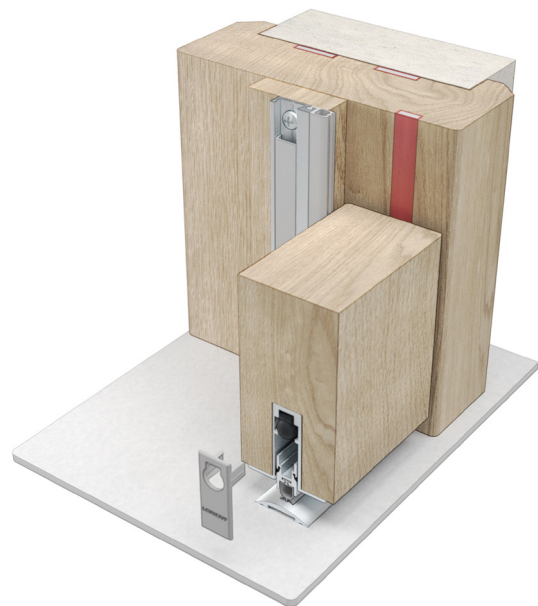
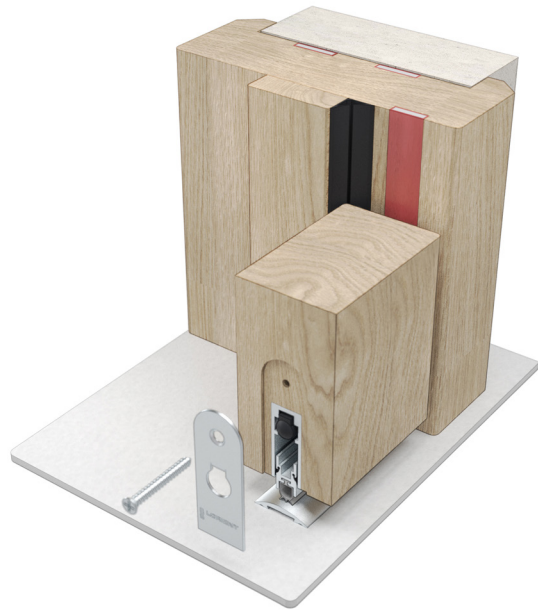

Threshold Seals

Effective sealing of the threshold gap is absolutely essential to meet the performance requirements for acoustic doors. An automatic threshold seal is the preferred solution, bearing in mind the need for minimal resistance to opening and closing movements. This can be face-fixed or concealed within the bottom rail of the door leaf.



Hinges and other ironmongery

As with smoke, neither the knuckle of a standard hinge, nor the door's latch will make a significant contribution to stopping sound transfer. In fact, with acoustic sealing it is even more important for seals to be uninterrupted at the ironmongery positions: quite tiny gaps can lead to unacceptable losses in performance. It's also important to ensure there is proper sealing at the top and bottom corners of the door.



REGULATORY REQUIREMENTS

Guidelines for acoustic performance are shown in the Approved Documents to the Building Regulations. The figures given are clearly stated to be minimum requirements, although they are widely interpreted as being absolute requirements.

Approved Document E

Approved Document E states a **minimum sound reduction performance of 29dB Rw** for door assemblies, when tested in accordance with BS EN ISO 10140:2010 and rated in accordance with BS EN ISO 717-1:2013

Building Bulletin 93

Building Bulletin 93 (an Approved Document that relates to the specific acoustic requirements for schools), states a **minimum of 30dB Rw**. For **music rooms, it's 35dB Rw**.



The occupants of a building will always be aware if an acoustic door is not providing an adequate level of sound reduction: unlike fire or smoke, building occupants live with sound containment issues every day. What's more, it's unlikely a door assembly will achieve the same performance on-site as it will in the laboratory, because it won't be installed in quite the strict way it would be in a test situation. So it's important to look for a higher level of acoustic performance than the minimum requirement, wherever possible.

Testing Procedures

To test for acoustic performance, a complete full-size door assembly is fitted in a wall between two rooms at a special test laboratory. In one room is a device that produces a controlled noise, and in the other a microphone that measures the amount of sound that passes through the door assembly. Measurements are taken across a range of frequencies, and the results are recorded in decibels. The tests are carried out in accordance with the internationally recognised standard, BS EN ISO 10140:2010.

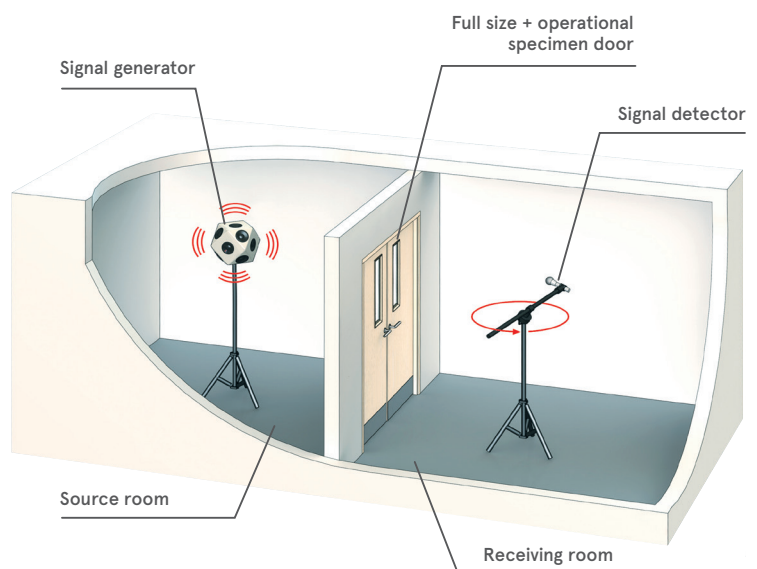

Using mathematical formulae described in another international standard (BS EN ISO 717-1:2013), the door assembly is then given a single figure acoustic performance rating – the “Weighted Sound Reduction Index”. This is specified as a number of dB followed by the suffix Rw – for example, 31dB Rw. This dB Rw figure is a convenient way of comparing the performance of one door assembly with another, but it does not give a full picture of the performance at any specific frequency – a separate graph is produced which shows this.

There is no ‘pass’ or ‘fail’ with an acoustic test: the test just gives a performance figure. Building Regulations Approved Documents (such as Approved Document E for England & Wales) will state the required dB Rw figure that’s needed in a particular situation.

As for fire tests and smoke tests, acoustic tests have to be carried out on complete, full-size door assemblies, including the leaf, frame, essential ironmongery, and the sealing system.

Test Reports

The tests must be conducted on the exact configuration of the door assembly that will be used in practice. A report issued for a test conducted on a single leaf door is not valid for a double leaf assembly. Apertures for glazing or letter-plates will also affect performance. Separate tests and separate reports are required for each configuration and should identify the sealing system used in each case.

Some seal suppliers make exaggerated claims for their products, particularly for threshold seals, implying that simply fitting their particular seal will bring about a vast improvement in acoustic performance. This is quite unrealistic – the performance requirements stated in the Approved Documents refer to complete door assemblies, and will be achieved through a combination of door construction and an overall sealing system. A threshold seal on its own cannot have a dB Rw rating.

Many acoustic door assemblies will also need to provide fire and smoke containment. This means that the door assembly will need to have three test reports:

- ▶ One for fire resistance under the conditions of BS 476 - 22;
- ▶ One for smoke control under the conditions of BS 476 - 31.1;
- ▶ One for acoustic performance under the conditions of BS EN ISO 10140: 2010, rated in accordance with BS EN ISO 717-1:2013.

Independent Accreditation

Acoustic testing doesn’t tell us how well the door assembly or sealing system will perform over time. Once the product has been installed in the building, will it keep on working and continue to meet the acoustic performance as stated in the test report, perhaps months or years into the future?

Every time the door is opened and closed, the sealing system will come under pressure, through the natural process of wear and tear. Unless it is well designed and well manufactured, the sealing system will significantly deteriorate more quickly than it should, the acoustic performance will be compromised, and the seals will need to be replaced. But this extra inconvenience and cost really shouldn’t be necessary if the sealing system has been designed with everyday use in mind.

Unfortunately, there is no recognised independent performance accreditation for an acoustic door assembly or an acoustic sealing system. But we can draw from experience in other sections of the industry. It is particularly useful to look at the accreditation schemes for smoke seals as a benchmark, because acoustic seals and smoke seals have so many similarities. Refer back to page 18 for the criteria.



ACTIVITY 5

1. What does dB Rw stand for and why is it used?
2. What is the minimum dB Rw stated in Approved Document E?
3. How do schools differ from this under Building Bulletin 93?
4. Can a typical brush type seal supply adequate acoustic protection?
5. Why should you aim for a higher rating than that laid down by the Approved Documents?
6. How many test reports are necessary for an FD30S door that has to provide acoustics?

Please refer to the feedback section on page 54 to compare your answers.



OTHER CONSIDERATIONS

THRESHOLD PLATES + RAMPS

A threshold plate is usually fitted to the floor immediately under the door leaf in its closed position. It provides a uniform, level surface, and helps to overcome small differences in surface height, or uneven floors. A ramp can be used instead of a plate where there are larger differences in floor heights. The threshold seal fitted into the door leaf can make contact with the plate or ramp, to help ensure the best possible smoke and acoustic seal.

Threshold plates are usually formed from an extruded aluminium or brass profile. Pressed stainless steel threshold plates are also used, particularly in areas that are likely to be well used.

A threshold plate will usually be bedded on a flexible grout. This helps to give extra cushioning, adds an acoustic benefit, and helps to level out a hard floor surface. Some plates are supplied with soft vinyl "feet" that serve the same purpose and make installation much easier.

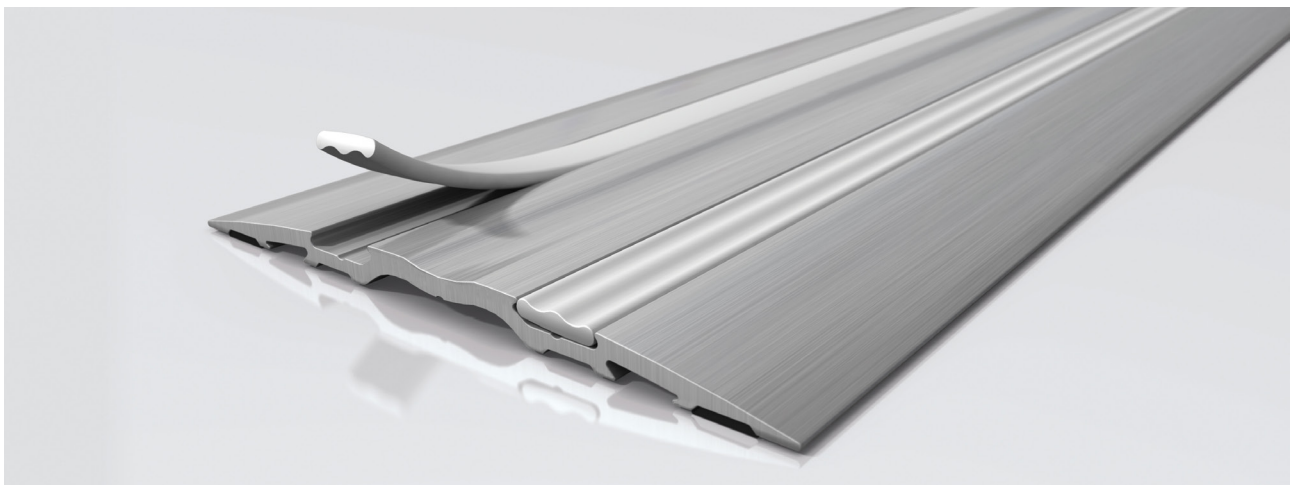
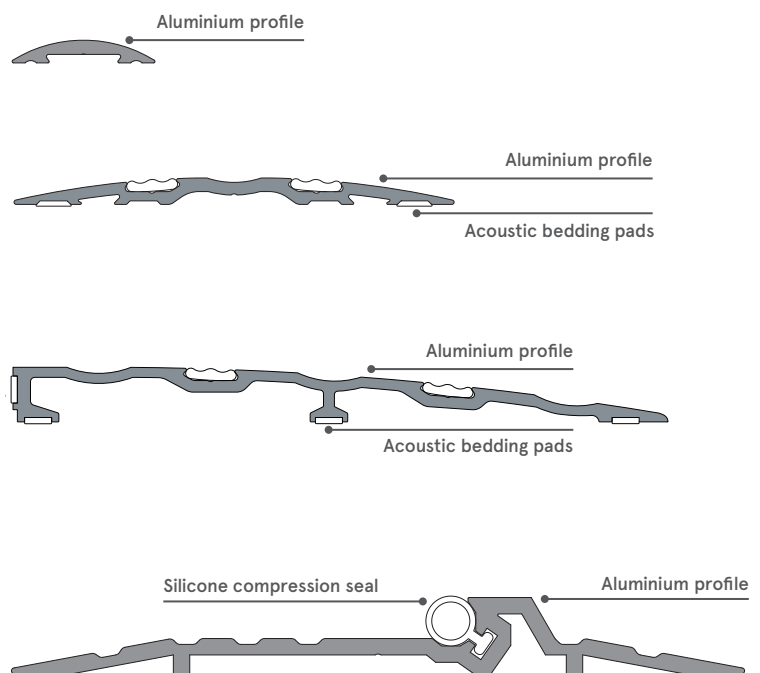

Anodised Finish

Some people think that because threshold plates are subject to foot traffic, there's no point in specifying a nice anodised finish, as they will quickly become scuffed anyway. In fact, the anodised surface is much harder than the more common "mill" finish. **An anodised product will not only last longer, it will better retain its surface finish and not show scuff marks so readily.**

Compliance

Approved Document M to the Building Regulations (England & Wales) is a major consideration. According to this Document, the threshold plate must not rise above 15mm in height from the floor. But from the point of view of those using wheelchairs, pushchairs or trolleys, a lower rise is better. 6mm is a readily-available dimension.

Vertical 'upstands' should be avoided if possible, particularly on interior doorways. While allowable in Document M, they can represent a trip hazard. Sometimes it is thought that a gasket in the upstand will provide additional acoustic benefits - but it may also add to the closing forces needed, and make the door difficult to latch. A good automatic threshold seal will give all the acoustic performance that's needed, and won't significantly add to the opening and closing forces either - so overall, it's a better option.

For ramps, the slope should be minimal. Most commercial products will be less than 15%.

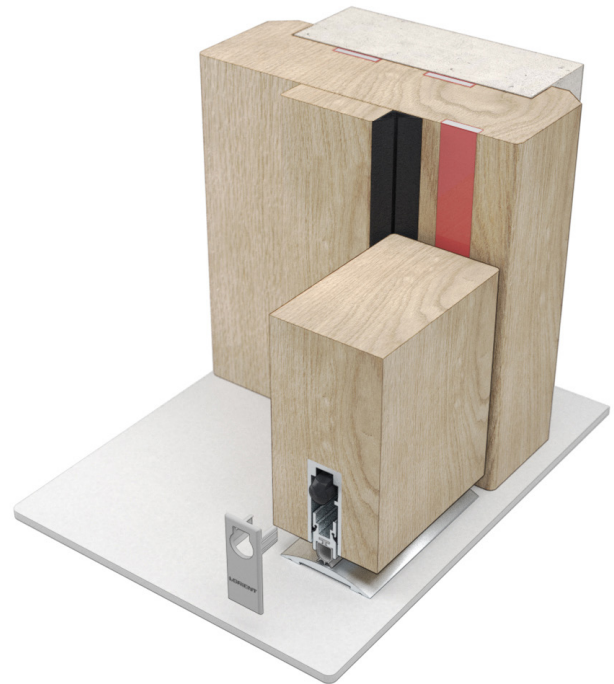

▲ Example of a threshold plate, shown as part of an acoustic, smoke + fire sealing system

ASTRAGALS

An astragal is a surface-mounted vertical cover strip designed to conceal the gap between the meeting stiles of single-acting, non-rebated, double leaf doors.

A typical astragal will consist of an aluminium holder, which is fixed to one of the stiles and will contain a resilient seal. This seal will compensate for any imperfection in the alignment of the two door leaves.

Because of its position on the door assembly, an astragal on a fire door will always be non-intumescent and used in conjunction with separate intumescent seals.

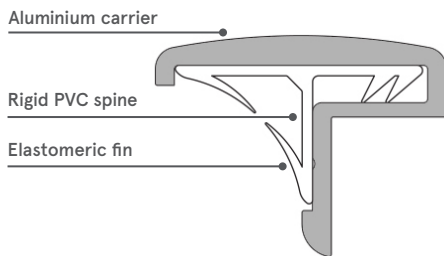

▲
Example of an astragal seal

BRUSH SEALS

Brush seals consist of relatively long, densely packed nylon filaments (very different in style from the shorter brush-style or pile smoke seals often seen as part of a combined fire and smoke seal). The brushes are held in place by a steel spine, and the whole brush assembly can be mounted in different designs of aluminium holder.

Brush seals are particularly useful for sealing large gaps, or gaps of varying dimensions. They are found mostly on sliding or revolving door assemblies, rather than hinged ones. They are not typically used for smoke or acoustic containment, but more for draught reduction or weather resistance on industrial doors.

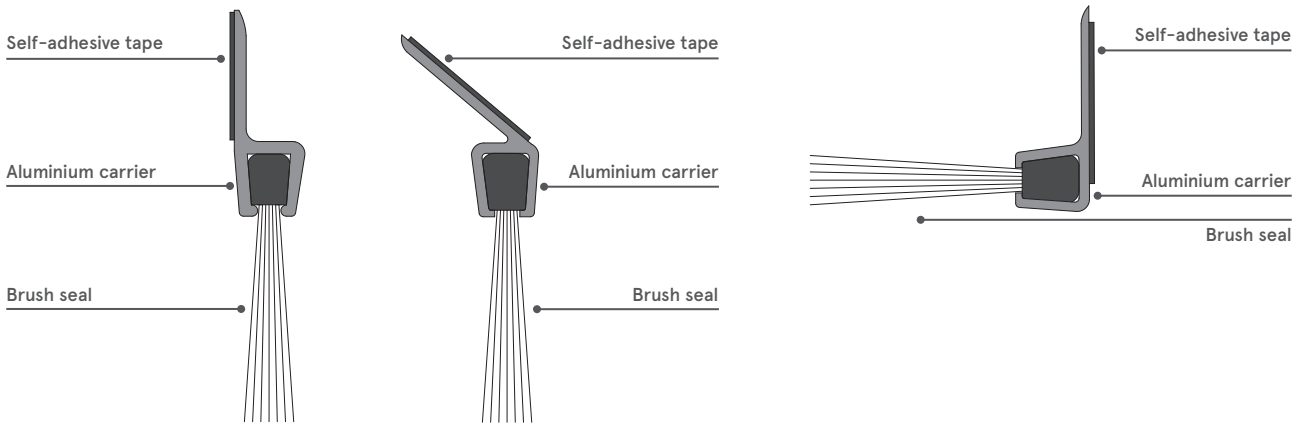

Example of a brush seal used at the threshold of a timber door

Brush seals in angle carriers, used in combination on a roller shutter door



FINGER GUARDS

Horrific injuries can occur when fingers become trapped in the gap between a door leaf and its frame, particularly on the hinged side of the assembly.

In commercial buildings, the risk of injury is quite low. But in any building used by, for example, children, elderly or visually impaired people, the chance of an accident is much higher. So in these situations it's wise to fit a finger guard which will cover the gaps, reducing the chance of an accident, and the temptation for fingers to explore. With society become ever more litigious, it's a wise precaution for building owners too.

There are many different designs of finger guards, but a typical architectural product will consist of a rubber gasket, attached to the door frame and leaf by some kind of carrier.

On the hinge cavity side (where a large gap will be exposed when the door opens), the gasket will be designed to extend across the gap, which will get wider as the door opens.

On the other side (the hinge knuckle side), a different geometry will be used for the gasket. The gap will not be anywhere near as wide, but still presents a very dangerous trap. The gap is still quite large enough to accommodate adult fingers when the door is opened by just 45°, and the leverage exerted by the door on this side is actually greater.

It's important to remember to protect both sides of the door – so finger guards should always be fitted as a pair.

It is also important to make sure the finger guard covers the whole height of the door edge. It is often assumed that small children are most vulnerable to the risk of trapped fingers but adults are quite frequent casualties, too.

Compliance

BS 8613:2017 (Finger protection devices for pedestrian doors - Type A, Class 2). This standard specifies requirements and test methods for the durability, strength and effective functioning of finger protection devices fitted at the hanging stile of pedestrian doors in public spaces, with the main purpose being to prevent accidental injury.

Independent accreditation

There are no independent accreditation schemes applicable to finger guards, but it is obviously important to have some indication of durability and consistency of manufacture from any supplier.

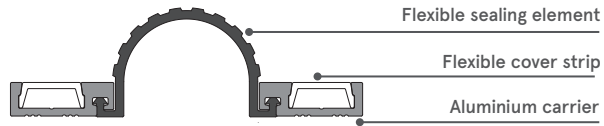

▲
LAS9050
Finger guard seal for the knuckle side



▲
LAS9030
Finger guard seal for the hinge cavity side



FRAMELESS GLASS DOORS

Frameless glass doors are frequently used in architectural situations. They are not generally suitable for fire, smoke or acoustic containment – a substantial hardwood or metal frame is usually essential for that. Edge seals are often required on glass doors though – for example to act as a buffer where two glass doors meet (as shown below), particularly on sliding doors. In this case, seals are usually only installed on the edges where the doors meet, as there's little benefit in putting them anywhere else on the door.

Special consideration needs to be given to Approved Document M to the Building Regulations (England & Wales). A sliding glass door is now required to have a clearly visible edge and it is no longer acceptable to fit the clear plastic products that have been popular in the past.

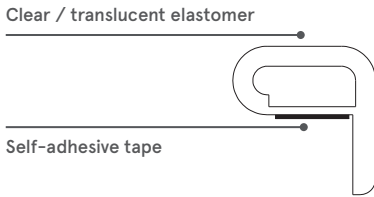

▲ Example of glass door seal

MISCELLANEOUS

It is important to be aware also of related items in a door assembly, such as glazed apertures; letter plates; security viewing devices; air transfer grilles etc; the presence of which may compromise fire, smoke, acoustic or security performance.



▲ Example of a fire + smoke resistant letterplate with intumescent liner + nylon brush seals



▲ Example of a fire + security resistant letterplate with intumescent liner + nylon brush seals tested to TS 008:2015

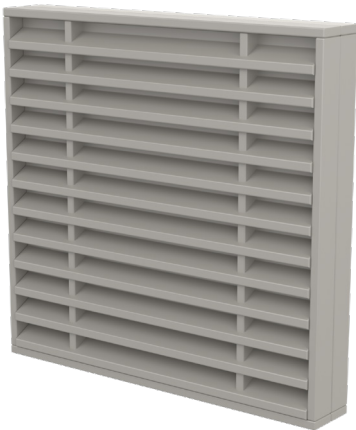

▲ Example of an intumescent air transfer grille



▲ Example of a 30 minute glazing system for a glazed aperture

ACTIVITY 6

1. Give two benefits of threshold plates with vinyl feet.
 - ▶
 - ▶
2. Why is an astragal seal necessary on pairs of doors?
3. Why should a finger guard be fitted to both sides of the door?
4. How does Approved Document M affect glass doors?

Please refer to the feedback section on page 54 to compare your answers.

SUMMARY

Today's architectural door assembly is heavily dependent on sealing systems for its performance, be that fire, smoke, acoustic or thermal containment. In choosing the right sealing solution, it's essential to make sure it's compatible with the door assembly.

The door manufacturer should be the primary source of information, and many door assemblies will be supplied with some or all of the seals pre-installed. Where there is any doubt or where further seals may need to be installed, always ask for the test evidence that verifies the performance.

Remember that separate test reports are required for fire, smoke and acoustics and, wherever possible, insist on independent quality accreditation to ensure ongoing performance and fitness-for purpose in everyday service.

And in case of any doubt – the Lorient Technical Services team will be happy to help!

Call our Technical Services team

+44 (0) 1626 834252





APPENDIX 1

METHODS OF MANUFACTURE

Architectural seals, holders and gaskets, are usually manufactured by an extrusion process. This is where materials are drawn out through a die, under conditions of considerable heat and pressure, to create a shaped linear profile, then cooled to maintain the shape.

In the case of aluminium, the extrusion process is generally followed by electro-chemical "anodising", which hardens the surface and creates a high quality finish, extremely resistant to pitting and corrosion.

Powder coating of extruded aluminium is possible too, and again creates a high quality, durable finish, and offers a wide choice of colours.



APPENDIX 2

MATRIX OF MATERIALS, PROPERTIES + FINISHES

MATERIAL	PROPERTIES	USES	FINISHES
ALUMINIUM	Strong, lightweight extrudable metal	Screw-fixed holders for resilient gasket materials. Threshold plates	Mill Satin anodised clear Satin anodised bronze Tough powder coated epoxy Tough powder coated polyester in an array of colours
BRASS	Strong, heavyweight extrudable metal	Special purpose threshold plates	Mill Bright polished Premium specials to individual order
STAINLESS STEEL	Highly durable heavyweight metal, not extrudable, formed to shape by pressing	Heavy duty threshold plates. Housings on some perimeter and threshold seals	Mill Satin brushed
RIGID PVC	Versatile rigid thermoplastic material – extrudable	Casings for intumescent seals, smoke seals, acoustic seals	Satin finish solid colours Woodgrain and metallic foils Specials to match nylon coated ironmongery
FLEXIBLE PVC	Versatile soft thermoplastic material – extrudable, flexible but not elastic	Sealing gaskets, bulbs, fins etc	Satin or gloss finish Black, various colours and clear
THERMOPLASTIC ELASTOMERS	Rubber-like thermoplastic material – extrudable	Sealing gaskets, bulbs, fins etc	Satin or matt finish Black, various colours and translucent
NEOPRENE RUBBER	Benchmark rubber material – extrudable, resilient and durable	Sealing gaskets, bulbs, fins etc	Satin or matt finish Black only
SILICONE RUBBER	High performance rubber material – extrudable, excellent resilience and durability	Sealing gaskets, bulbs, fins etc	Black, grey, clear
POLYCARBONATE	Specialist, highly impact resistant thermoplastic material – extrudable	Holders for gaskets and buffer strips on glass doors	Gloss finish Generally clear Colours also available

APPENDIX 3

Glossary of terms.

A

ACOUSTIC SEAL

Any seal designed to reduce airborne sound transmission.

ADE: APPROVED DOCUMENT E

Approved Document E to the Building Regulations (England) - Resistance to the passage of sound.

ADM: APPROVED DOCUMENT M

Approved Document M to the Building Regulations (England) - Access to and use of buildings.

AIRBORNE SOUND

Sound waves carried through air rather than a solid medium

AGEING RESISTANCE

The ability to withstand degradation in service, tested through exposure to a particular environment.

AMBIENT TEMPERATURE (SMOKE)

Smoke encountered some distance from the origin of a fire, and which has cooled but remains toxic.

ANODISED

A hard, highly durable, electrolytic finish applied to aluminium extrusions, which greatly enhances the appearance at the same time. It is naturally clear, giving a silver effect, but coloured tints such as bronze, gold or gunmetal may be incorporated, generally at extra cost.

ASTRAGAL

A face-fixed vertical cover strip designed to conceal the gap that would otherwise exist between the meeting stiles of single-acting, non-rebated, double leaf doors.

AUTOMATIC DOOR BOTTOM

A threshold seal that automatically retracts from the floor surface as soon as the door leaf is opened by a few millimetres, and generally requires no electrical connections.

AUTOMATIC THRESHOLD SEAL

A threshold seal that automatically retracts from the floor surface as soon as the door leaf is opened by a few millimetres, and generally requires no electrical connections.

B

BBA

British Board of Agrément – the premier independent quality assurance certification authority, which addresses relevant factors contributing to the fitness-for-purpose of building products.

BRITISH STANDARD

An official reference which may address either a recognised method-of-test or a code-of-practice.

BS

British standard, an official reference which may address either a recognised method-of-test or a code-of-practice.

BS EN

A British standard which is also identical to the relevant European Norm.

B

BS EN ISO

A British standard which is not only identical to the relevant European Norm, but also to the internationally recognised ISO standard.

BRUSH SEAL

Depending on the context, either: A seal element composed of nylon filaments, generally a minimum of 10mm long, and crimped into a metal spine – these are sometimes called ‘sweep action brushes’; or A short brush pile insert, fitted into an intumescent seal to provide smoke containment.

C

CARRIER

Any metal or plastic holder for a seal element.

CERTIFIRE

An independent quality assurance certification authority, which addresses relevant factors contributing to the fitness-for-purpose of products used in either fire or smoke protection. (Aligned with and managed by Exova, formerly known as Bodycote WarringtonFire Ltd.)

CLEARANCE GAP

The gap between a door leaf and its frame, or between the door leaf and the threshold.

COMPARTMENTATION

The division of a building into areas by using solid walls and floors to prevent the spread of fire and/or smoke.

COMPRESSION SEAL

A seal that becomes effective when a compressive force is applied to it – eg, when a door leaf closes onto it.

CONCEALED THRESHOLD SEAL

An automatic threshold seal designed to be mortised into the bottom of a door leaf where it is hidden from view.

COVER STRIP

A removable metal or plastic strip incorporated into a seal holder, intended to cover up unsightly screw fixings after the seal has been fitted and adjusted.

COVER PLATE

A removable metal or plastic plate designed to clip over the whole of a seal body, to cover screw fixings and give a smooth overall appearance.

D

dB

Decibel – a comparative measurement of sound intensity, generally referring to a reduction measured from one point to another.

dB(A)

An independent quality assurance certification authority, which addresses relevant factors contributing to the fitness-for-purpose of products used in either fire or smoke protection. (Aligned with and managed by Exova, formerly known as Bodycote WarringtonFire Ltd.)

DOCUMENT B

An “Approved Document” containing recommendations for demonstration of compliance with the Building Regulations (England & Wales) with respect to fire precautions.

DOCUMENT E

An “Approved Document” containing recommendations for demonstration of compliance with the Building Regulations (England & Wales) with respect to acoustic provisions.

DOCUMENT M

An "Approved Document" containing recommendations for demonstration of compliance with the Building Regulations (England & Wales) with respect to access provisions, particularly for people with limited mobility.

DOCUMENT Q

An automatic threshold seal designed to be mortised into the bottom of a door leaf where it is hidden from view.

DOUBLE ACTION

Refers to door assemblies in which the leaves are able to open in both directions of pedestrian travel.

DROP SEAL

An alternative expression for an automatic threshold seal.

E

ELASTOMER

Any material with rubber-like qualities of elasticity.

ESCAPE ROUTE

A fire and smoke protected area of a building, leading to a place of greater safety.

ESSENTIAL IRONMONGERY

Any hardware items such as hinges, latch, hydraulic closer, etc, essential to the operation of a fire resistant door assembly.

EXTRUSION

A profile of constant cross-section and indefinite length, created by forcing a billet of metal, or pellets of a thermoplastic material, through a shaped die.

F

FD30

A door assembly rated at 30 minutes fire resistance when tested in accordance with BS 476-22.

FD30S

A door assembly rated at 30 minutes fire resistance when tested in accordance with BS 476-22, with additional smoke resistance when tested in accordance with BS 476-31.1.

FACE-FIXED

Door furniture or seals mounted directly on the surface of the door leaf.

FINGER GUARD

A device covering the gap between a door leaf and its frame on the hinged edge, extending and contracting with the movement of the door. Its purpose is to provide protection from the risk of fingers being accidentally caught in the gap if the door should suddenly close.

FIRE RESISTANCE

The ability of a door assembly to withstand exposure to fire when tested in accordance with a recognised standard.

FIRE SEAL

A profile of constant cross-section and indefinite length, created by forcing a billet of metal, or pellets of a thermoplastic material, through a shaped die.

FLUSH BOLT

A flush bolt is a security device to be used on pairs of doors to secure the inactive leaf. It is activated lever, that drops the bolt into a keep in the floor.

FREQUENCY

The character of a sound wave referring to the number of vibrations or cycles per second and measured in Hertz.

G

GASKET

The flexible element associated with a seal profile, usually for smoke and/or acoustic containment.

H

HEAD

The top of a doorway and part of the perimeter seal system.

HERTZ [HZ]

The unit of measurement for the frequency of a sound wave in cycles per second – eg, 3000 cycles per second = 3000 Hz.

HOUSING

A casing or other form of retention for a seal element.

I

IFC

An independent quality assurance certification, which addresses relevant factors contributing to the fitness-for-purpose of products used in either fire or smoke protection. (Managed by International Fire Consultants Ltd.)

INDEPENDENT ACCREDITATION

Quality assurance certification which addresses many factors relating to serviceability and fitness-for-purpose of a product, going beyond the passing of a single fire, smoke or acoustic test.

INTEGRITY

The capacity of a door assembly to maintain its resistance to fire or smoke exposure over a period of time.

INTUMESCENT

A material which does not immediately melt on exposure to elevated temperature but first expands to a cellular structure many times its original volume, sometimes accompanied by pressure development.

J

JAMB

The vertical portion of the frame onto which the door is secured.

K

KEEP

An alternative word for a staple or strike plate i.e. the part of the lock which receives the bolt and secures the door.

L

LEADING EDGE

The closing edge of a door which meets the doorframe.

M

MEETING STILE

The vertical edges of double doors at the point they meet, defining the gap between them.

MILL FINISH

The surface of a metal component after forming it to shape and without any further decorative or protective treatment.

N

NEOPRENE

The vertical edges of double doors at the point they meet, defining the gap between them.

NYLON

A hard thermoplastic material, widely used in the form of filaments for sweep action brush seals.

NEWTON

The surface of a metal component after forming it to shape and without any further decorative or protective treatment.

O

OPERATING RESISTANCE

The force needed to overcome the resistance to opening and closing of a door assembly, caused by the combined presence of seals and essential ironmongery.

OPENING AND CLOSING FORCES

The force needed to overcome the resistance to opening and closing of a door assembly, caused by the combined presence of seals and essential ironmongery.

P

PVC

Poly Vinyl Chloride – a thermoplastic material, commonly used in seal assemblies, which may be in varying degrees of hardness or softness as required.

PVCU

Hard “unplasticised” PVC material, widely used in the housings for intumescent seals.

PERIMETER SEAL

A seal located on the long edges and across the head of a door assembly.

PILE SEAL

A flexible smoke or weather seal element made from short polypropylene fibres and generally incorporated in a rigid PVC or aluminium holder. See also brush seal.

POLYMER

A synthetic mouldable material of either rubber or thermoplastic.

POLYPROPYLENE

A thermoplastic material widely used in the manufacture of fibres for flexible pile (brush) seal elements.

R

RW

An acoustic measurement denoting the “weighted average sound reduction index” and used to describe the performance of a door assembly over a range of frequencies, but expressed as a single comparable figure – eg, 29dB Rw.

RAIL

A horizontal reinforcing element in a door leaf construction.

RAMP

A sloping plate used to facilitate a smooth transition from one floor level to another.

REBATE

The part of a door frame created by the presence of the stop, and forming a recess for the edges of the door leaf.

RESILIENCE

The ability of a flexible sealing element to recover quickly from deformation caused by compression or other locally applied force.

REVEAL

The side of the door frame, revealed by opening the door.

S

SANTOPRENE

A highly resilient and very durable thermoplastic material, closely resembling Neoprene rubber in its properties.

SATIN ANODISED

A hard, durable, electrolytic finish applied to aluminium extrusions which greatly enhances the appearance by imparting a satin sheen. It is naturally clear, giving a silver effect, but coloured tints such as bronze, gold or gunmetal may be incorporated to order.

SINGLE ACTION

Refers to door assemblies in which the leaves are able to open in just one direction of pedestrian travel.

SMOKE SEAL

Any seal designed to greatly reduce the transmission of smoke from one side of a door assembly to the other.

SOUND PRESSURE

The property of airborne sound which, combined with frequency, determines how easily it will transfer from one side of a door assembly to the other.

SOUND WAVE

Refers to airborne sound in the form of a longitudinal wave, having a frequency and an amplitude.

STILE

A vertical reinforcing member in a door leaf – but also a commonly- used reference to the outside vertical edge of a door leaf.

STC

Sound Transmission Class. A single figure performance indicator very similar to Rw but derived from ASTM-E413 Classification for rating sound insulation.

STOP

The raised part of a door frame which prevents the leaf from swinging any further than needed to achieve the full closed position.

T

THERMOPLASTIC

A synthetic material which can be formed to a specific shape by applying heat and compression – eg, by injection moulding or extrusion.

THRESHOLD GAP

The clearance necessary for everyday operation at the bottom of a door leaf.

THRESHOLD SEAL

Any seal designed to bridge the threshold gap when the door leaf is in the closed position.

THRESHOLD PLATE

A metal strip designed to fit across the doorway to form a level surface on which a better sealing efficiency may be achieved. It may also provide a transition from one floor surface to another.

U

UL

UL is a global independent safety science company that tests a diverse range of products; representative samples of a product must be tested and meet UL's stringent requirements to carry the marque. These requirements are based primarily on UL's published and nationally recognised Standards for Safety.

UPVC

Hard "unplasticised" PVC material, widely used in the housings for intumescent seals.

V

VINYL

A particular type of chemical group but commonly used as a shortened expression for Poly Vinyl Chloride.

W

WIPING SEAL

A seal element that becomes effective as the door leaf completes a wiping motion across it.

WOODGRAIN

A decorative finish applied to a seal casing or holder, simulating a timber veneer.

ACTIVITY FEEDBACK

ACTIVITY 1

1. Choose from the following:
 - ▶ Single leaf, single acting.
 - ▶ Single leaf, double acting.
 - ▶ Double leaf, single acting.
 - ▶ Double leaf, double acting.
 - ▶ Sliding.
2. ▶ Gaps are larger at the threshold.
 - ▶ The threshold area does not have the benefit of a door stop.
 - ▶ Accessibility requirements.

3. Your drawing should look something like this:

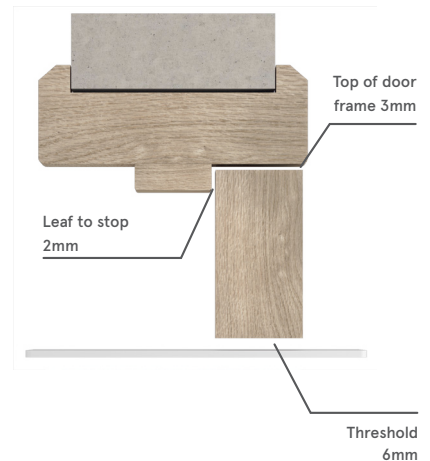

ACTIVITY 2

1. Refer to current Building Regulations for England and Wales.
These can be found here:
www.lorientuk.com/resource-centre/building-regulations
2. Refer to current Building Regulations for Northern Ireland and Scotland.
These can be found here:
www.lorientuk.com/resource-centre/building-regulations

ACTIVITY 3

1. ▶ Seals help prevent door distortion.
 - ▶ Seals protect metal ironmongery from radiating heat.
 - ▶ Gaps are closed to prevent the flow of oxygen to the source of the fire.
2. ▶ Retrofit situations rather than factory fit.
 - ▶ Where doors are sold separately from the frame.
 - ▶ Meeting stile location.
3. ▶ Hinges
 - ▶ Latch
 - ▶ Self-closing device.
4. When an FD90 or FD120 door is used (for the longer periods of fire rating).

ACTIVITY 4

- ▶ Combined with a fire seal, centrally in the door leaf or reveal of the frame.
 - ▶ Offset in the reveal of the frame if it's a separate smoke seal.
 - ▶ On the door stop – either in the corner (rebate) or mounted on the stop.
- Ironmongery points act as straight-through gaps for smoke, so must be protected.
- Approved Document M states that doors on accessible routes must not be difficult to open, so the opening / closing forces need to be as low as possible by using low friction seals.
- ▶ Quality of manufacture.
 - ▶ Continuously tested product in a range of applications.
 - ▶ Durability, cycling.
 - ▶ Marked for easy identification (for maintenance / replacement purposes).

ACTIVITY 5

- Weighted Average Sound Reduction Index, used to compare the performance of one door assembly with another.
- 29dB Rw.
- The rating is increased to 30dB Rw, and 35dB Rw for music rooms.
- No – brush type seals only perform at 23dB Rw.
- ▶ Performance in a laboratory is difficult to replicate on site.
 - ▶ The ratings laid down are minimum requirements only.
 - ▶ Ongoing acoustic performance is more likely if you aim higher.
- Three – one for fire, one for smoke, one for acoustics.

ACTIVITY 6

- ▶ Cushioning and levelling on uneven surfaces.
 - ▶ Acoustic benefits.
- Smoke and acoustic protection.
- Gaps are large enough on the knuckle side to get fingers in.
- Doors must have visibly defined leading edges.

NOTES

NOTES

ADDITIONAL INFORMATION

TECHNICAL REFERENCES

Lorient is quality assured under the disciplines of BS EN ISO 9001: 2015.

Accreditation to this standard is an assurance that we conduct our business to the complete satisfaction of our customers with regard to design solutions, manufacturing consistency and management procedures.

As a result, this internationally recognised standard for quality management generates customer confidence. Regular audits of our company procedures are undertaken by qualified BSI staff to ensure ongoing compliance with all aspects of the standard.



BS EN ISO 9001: 2015 Certificate No. Q6104

Lorient has attained the BS EN ISO 14001: 2015 accreditation for environmental management, making us the first seal manufacturer to have achieved this important award. This internationally recognised standard shows that we have demonstrated our commitment to responsible environmental behaviour, including prevention of pollution, control and reduction of waste, and ongoing monitoring and improvement of our environmental performance. Achieving ISO 14001 is just one part of our ongoing commitment to operate in a sustainable way.



BS EN ISO 14001: 2015 Certificate No. EMS 541906

MADE IN BRITAIN

We are proud to have been granted the prestigious Made in Britain marque for our products, designed and manufactured at our main facility in South West of the UK.



TRADE ASSOCIATIONS

Lorient is a member and active contributor to the following:



ASSOCIATION OF COMPOSITE DOOR MANUFACTURERS



Qualifying Fire Door Professionals

ACCREDITATIONS

BBA

BBA approvals provide independent assurance for the designer, specifier and end-user as to the 'fitness for purpose' of building products.



CERTIFIRE

Operated by Exova Warringtonfire, CERTIFIRE is an accredited independent product conformity scheme that requires products to meet the requirements of the tests, to add minimal resistance to opening and closing forces, to prove long term performance under a variety of service conditions, and to be permanently marked for easy identification.



IFC

IFC Certification Ltd is a UKAS approved and internationally recognised provider of third party Certification services – designed to give confidence to specifiers, users, occupiers, owners and enforcement bodies that products have been thoroughly and independently evaluated and will continue to be manufactured to the same specification as originally tested.



UL

UL is a global independent safety science company that tests a diverse range of products; representative samples of a product must be tested and meet UL's stringent requirements to carry the marque. These requirements are based primarily on UL's published and nationally recognised Standards for Safety. Businesses, consumers and regulatory authorities around the world recognise the trusted rigour and technical excellence of UL certifications. Lorient is proud to have achieved the UL Mark on many of its products. These are detailed on individual pages.



COMPREHENSIVE SUPPORT

We continue to lead the way in Research + Development. As a company we have 40 years' experience, so our experts are well equipped to listen, help and advise you on your sealing system requirements.

Technical Services

We're happy to provide specialist advice on acoustic, smoke and fire protection for refurbishment and new build projects. If you need assistance, you can call our Technical Services team.

Alternatively, we can arrange a site visit to get a clearer idea of your needs and how we can help you. We also provide copies of test reports and samples where needed; and can give guidance on how best to meet Building Regulations and Standards.

Fire Door Inspection Services

We also offer a professional and expert fire door inspection service. Our Certificated Fire Door Inspectors are fully qualified under the Fire Door Inspection Scheme (FDIS); and have been assessed by Exova Warringtonfire, an independent third party. They are certificated to carry out the inspection of your building's fire doors and prepare a detailed survey and report on the condition and function of the fire doors on your premises. This is invaluable if you're a Responsible Person in a building. Contact us for more details.



Web Support

Our website features a comprehensive range of supporting documents covering the entire range of products, including installation guides and CAD drawings. All of our brochures and products sheets are also available for download, together with copies of certification and specification texts.

Online Acoustic Search tool

Our Acoustic Search tool on our website gives you quick and easy access to a wide range of tested acoustic sealing systems on a variety of popular door constructions & configurations.

www.lorientuk.com/acousticsearch

The tool allows users to select a specific decibel rating; along with door configuration, fire door rating, doorset type etc to filter the results. The 'Acoustic Search' tool is updated frequently with Lorient's ever-expanding portfolio of test evidence. If you're looking for high performance or specialist applications – please contact us on **+44 (0)1626 834252**, there may be some additional configurations we haven't yet published.



Customisation

If you have a particular requirement which isn't covered by the applications in this brochure, we may be able to supply an existing non-standard item, or even develop a customised solution for you. Utilising in-house expertise, bespoke products are created to your requirements; from a functional or aesthetic perspective, or both.

Lorient's dedicated Technical Services team supports and works as part of your design team, offering informed product advice and guidance on regulatory requirements and standards.



Call our Technical Services team
+44 (0)1626 834252

www.lorientuk.com

CPDs

We offer three fully-accredited CPD seminars. Impartially presented by knowledgeable speakers, the seminars are structured to be technically informative, and provide practical advice.



Performance Door Design: The Basics of Sound Reduction

Effective acoustic containment helps to improve the quality of the built environment, preserving privacy as well as excluding unwanted noise. With changing regulations, it's essential to be informed of the relevant requirements and the implications for door assemblies.

Our acoustic CPD seminar covers:

- ▶ the nature of sound, examining airborne transmission of sound;
- ▶ regulatory requirements and British Standards that relate to acoustic performance;
- ▶ test procedures and interpretation of test reports;
- ▶ effective design of door assemblies for acoustic performance, including door construction and the influence of sealing systems;
- ▶ design conflicts between acoustic performance, durability and ease of operation of the door;
- ▶ independent accreditation.

The Role and Performance of Fire and Smoke-Resisting Door Assemblies

The importance of fire and smoke resisting door assemblies is illustrated by the 303 fire related fatalities and 7,661 casualties in fires (2015/16). Apart from the human toll, property losses each year approach £2.52 billion.

Our fire and smoke containment CPD seminar covers:

- ▶ hard facts concerning deaths, injuries and property damage caused by fire and smoke;
- ▶ regulatory requirements for fire and smoke resisting door assemblies;
- ▶ the nature and behaviour of smoke;
- ▶ effective design of door assemblies for smoke containment, including the threshold gap;
- ▶ design conflicts between fire containment, smoke containment, durability and ease of operation of the door;
- ▶ independent accreditation.

The Regulatory Reform (Fire Safety) Order 2005 and its implications for fire doors

The RRO consolidated 70 pieces of legislation; shifted responsibility for fire safety management; abolished the Fire Safety Certificate; established the Fire Risk Assessment and created major change in legal liability.

Our RRO CPD seminar covers:

- ▶ an overview of the RRO;
- ▶ product solutions;
- ▶ the dangers of fire and smoke;
- ▶ the importance of fire doors – including installation and maintenance.

Our CPD materials have been independently verified and certified by the RIBA as CPD approved. A certificate for 1 hour's CPD will be provided, which contributes to Continuing Professional Development requirements.

If you are interested in booking a seminar, please contact our Marketing department or email cpd@lorientuk.com.

TO
NG
MS



UK / EUROPE

T: +44 (0) 1626 834252
F: +44 (0) 1626 833166
E: mktg@lorientuk.com

AUSTRALIA

T: +61 (02) 9907 6221
E: sales@lorientau.com.au

HONG KONG

T: +852 2505 0328
F: +852 2505 0332
E: sales@lorienthk.com

SINGAPORE

T: +65 6270 1279
E: sales@lorient.com.sg

UAE

T: +9714 883 7206
F: +9714 883 7207
E: sales@lorientgulf.ae

USA

T: +1 859 252 7441
F: +1 859 381 1241
E: inquiries@lorientna.com

For further information about
Lorient products please visit:
www.lorientgroup.com



@LorientUK



/company/lorient



@lorientuk



/LorientPolyproducts

ASSA ABLOY

An ASSA ABLOY Group Brand